

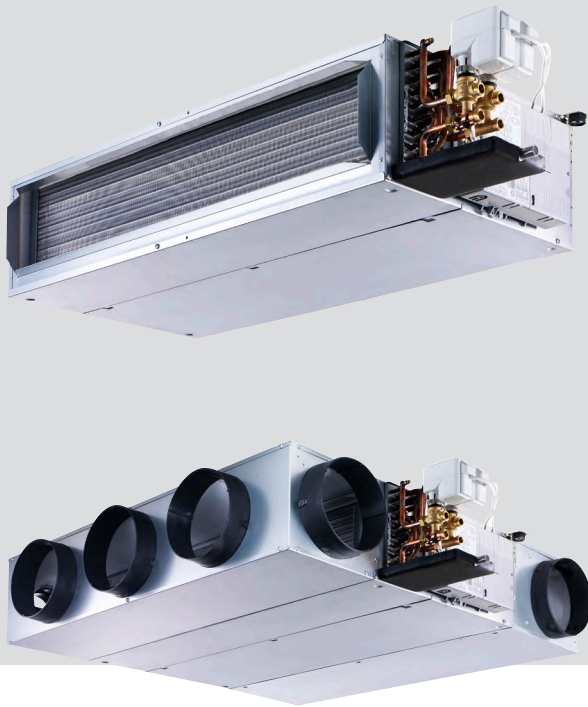

United Technologies

PRODUCT SELECTION DATA



- Modular Horizontal ducted unit
- Extremely quiet operation
- Low Energy Consumption
- Flexibility for simplified installation
- Improved comfort
- Efficient Indoor Air Quality

Hydronic Ducted Fan Coil Units

42NL & 42NH



CARRIER participates in the ECP programme for FC/FCP
Check ongoing validity of certificate:
www.eurovent-certification.com  www.certiflash.com



Contents

1 - FUNCTIONS AND CONFIGURATIONS	3
1.1 - Modularity	3
1.2 - Configuration flexibility.....	3
1.3 - Standard spigots configuration	4
2 - DIMENSIONAL DRAWINGS	8
3 - MAIN MODULES AND COMPONENTS	11
3.1 - Casing	11
3.2 - Fan motors.....	11
3.3 - Fan wiring solutions	11
3.4 - Water coil.....	12
3.5 - One-piece condensate drain pan	12
3.6 - Filter.....	12
4 - OPTIONS SPECIFICATIONS	13
4.1 - Electric heater (option for 2-pipe coil).....	13
4.2 - Fresh air controller (option)	13
4.3 - Valves and actuators (option)	14
4.4 - Flexible water pipes (option).....	16
4.5 - Sensors (option)	16
4.6 - Condensate pump (option)	16
5 - CONTROL (OPTION)	17
6 - PRODUCT CHARACTERISTICS LIST	18
7 - 42NH AND 42NL PERFORMANCE DATA	20
7.1 - Physical and electrical data at Eurovent conditions - 42NL - Sizes 2 and 3.....	20
7.2 - Physical and electrical data at Eurovent conditions - 42NL - Size 4.....	21
7.3 - Physical and electrical data at Eurovent conditions - 42NL - Size 5.....	22
7.4 - Physical and electrical data at Eurovent conditions - 42NH - Sizes 2 and 3	23
7.5 - Physical and electrical data at Eurovent conditions - 42NH - Size 4	24
7.6 - Physical and electrical data at Eurovent conditions - 42NH - Size 5	25
7.7 - Physical and electrical data at Eurovent conditions - 42NH - Sizes 6 and 7	26
7.8 - Thermal capacities.....	27
7.9 - Sound power levels.....	36
7.9 - Sound power levels (continued)	37
7.10 - Electrical data	39
7.11 - Water coil pressure drop.....	49
7.12 - Air flow data.....	50
8 - OPERATING LIMITS	55
9 - SPECIFICATION GUIDE 42NL/42NH	56
General description	56
Technical specification	56

The photograph on the front cover is for illustrative purposes only and is not part of any offer for sale or contract. The manufacturer reserves the right to change the design at any moment without prior warning.

1 - FUNCTIONS AND CONFIGURATIONS

- The Carrier 42NH and 42NL are available in different sizes with 2-pipe, 2-pipe plus electric heater or 4-pipe coils, with an air flow range from 100 to 2300 m³/h, a total cooling capacity range from 0.6 kW to 12 kW and a nominal heating capacity range from 0.8 kW to 17 kW.
- Compact and modular ducted unit, designed for any false ceiling installation.
- Reliable and economical for tertiary building as hotel guest rooms, offices or light commercial applications.
- Low height of 235 mm (sizes 2/3/4/5) and 285 mm (sizes 6/7)
- Compatible with the Carrier diffuser ranges.
- Extremely low sound levels for ducted applications.
- Five- to Six- speed fan AC motors offers a wide choice of medium speeds.
- Available with Low Energy Consumption variable-speed EC motor.
- High-pressure centrifugal fan for 42NH Range
- G1 filter as standard.
- Safe factory installed electric heater with multiple capacity stages choices.
- Low water pressure drop with factory installed valves.
- Factory installed options (valves and controllers) for fast and easy installation in false ceilings.

1.1 - Modularity

With its two versions, the range is able to address all applications.

The 42NL version is optimised for simple soffit installations while the 42NH is optimised for air return and supply ducted installations.

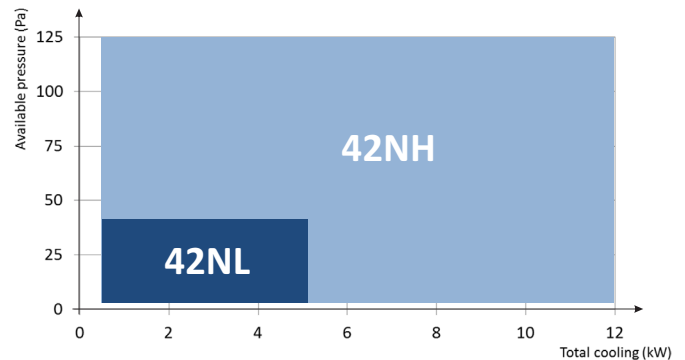

1.2 - Configuration flexibility

Each of the 42NL and 42NH sizes can be provided:

- With free inlet and/or outlet
- With a rectangular flange air inlet and/or outlet (practical to connect the fan-coil unit to the air ductwork).
- With inlet and/or outlet plenums including large number of spigots diameters 160, 200 or 250 mm according to unit size.

Below picture shows all available air distribution configurations on 42NL or 42NH (size 3 for example) with spigot diameter 200 mm.

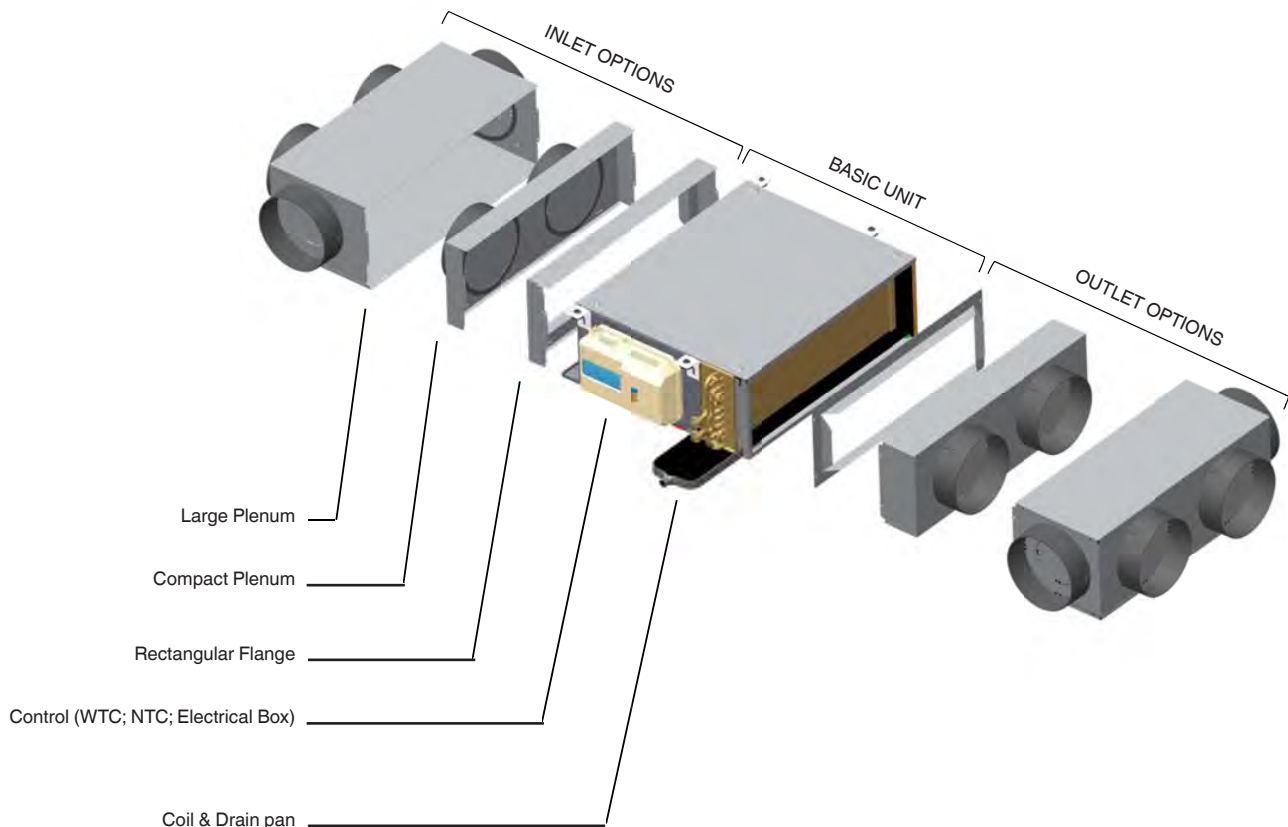

1.3 - Standard spigots configuration

Large and small plenums for inlet and outlet are available for all sizes according to the drawings below:

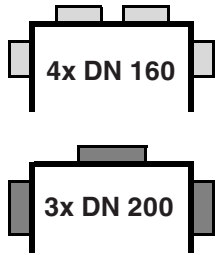
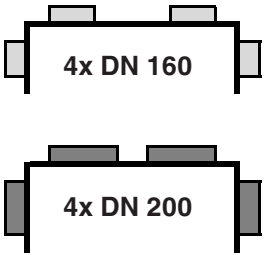
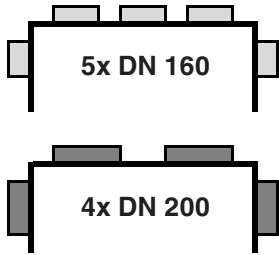
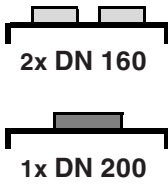
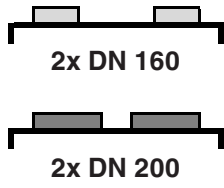
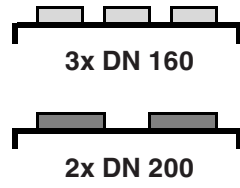
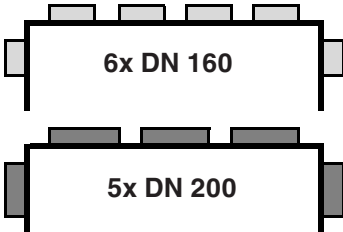
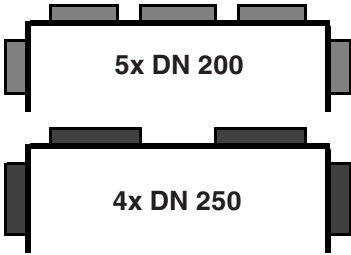
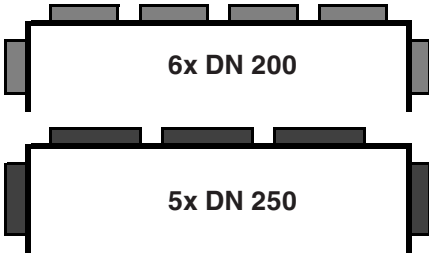
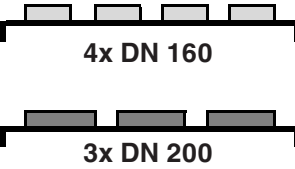
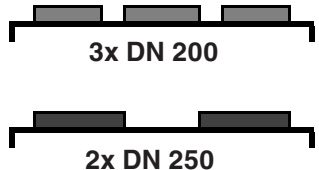
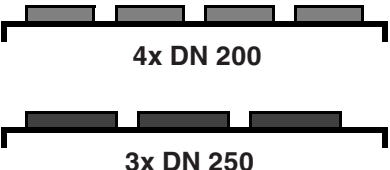
	42NH & 42NL Size 2xx	42NH & 42NL Size 3xx	42NH & 42NL Size 4xx
LARGE INLET OR OUTLET			
			
LIMITS (*)	MIN. SPIGOTS. = 1x160 or 1x200 (2x160 and 1x200 for 42NH279)	MIN. SPIGOTS. = 2x160 or 1x200 (2x160 and 2x200 for 42NL range)	MIN. SPIGOTS. = 3x160 or 2x200
	42NH & 42NL Size 5xx	42NH Size 6xx	42NH Size 7xx
LARGE INLET OR OUTLET			
			
LIMITS (*)	MIN. SPIGOTS. = 3x160 or 2x200 (4x160 and 3x200 for 42NL range)	MIN. SPIGOTS. = 3x200 or 2x200	MIN. SPIGOTS. = 4x200 or 3x250

(*) = Minimum number of spigots required to ensure sufficient available static pressure and fan reliability

NOTE:

- Electrical heater are not available for 42NL Units when plenum are selected (due to minimum airflow requirement)
- Non-standard configurations not listed above can be provided upon special request. Contact your local Carrier representative.

Standard spigots configuration (Continued)

Standard Configuration with inlet and outlet rectangular flanges:

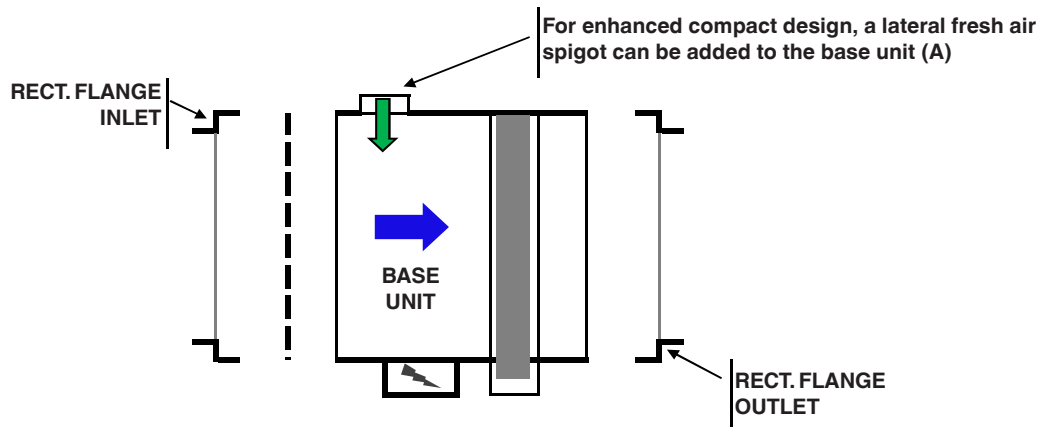

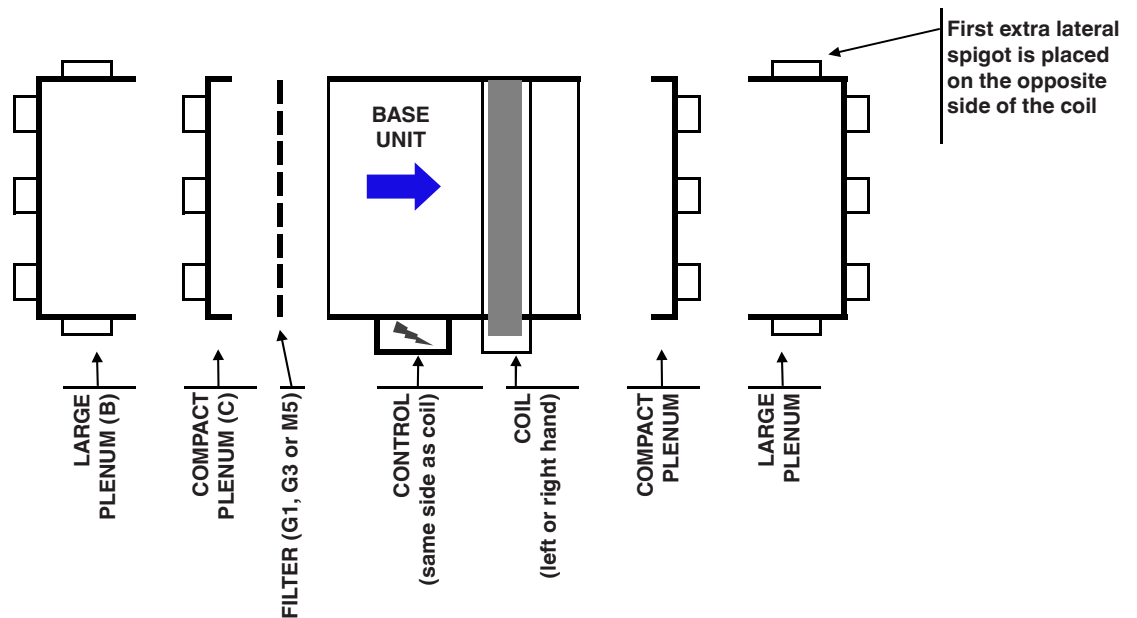

Standard Configuration with spigots without fresh air:

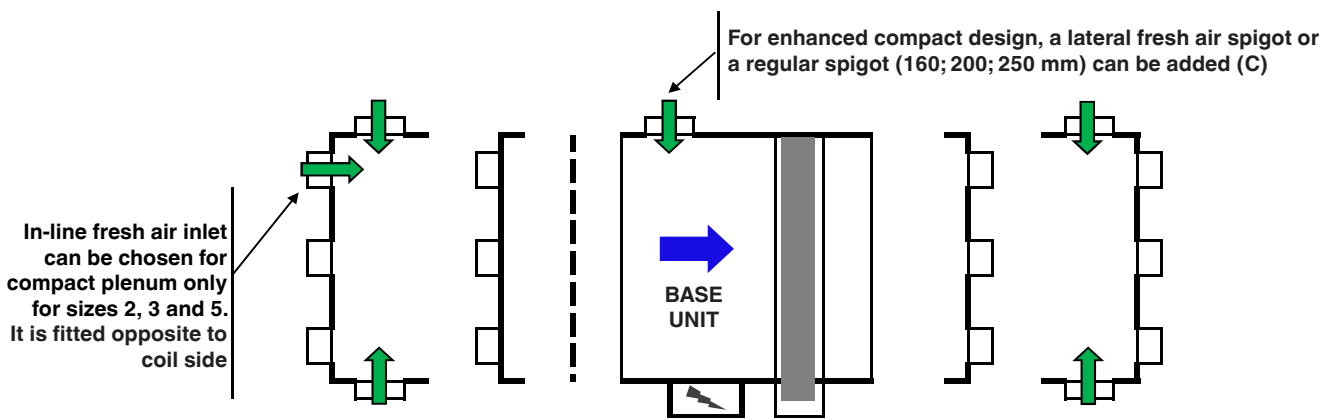

Standard Configuration with fresh air inlet possibilities:



-  Air flow direction
-  Fresh air inlet

- (A) In this case, the air must be filtered beforehand to prevent any damage to the fan and the soiling of the coil.
- (B) Large plenum is required to fit the M5 filter
- (C) Without any filter the small inlet plenum is flat for improved compacity.

Standard spigots configuration (Continued)

Useful configurations are displayed below:

U-shaped

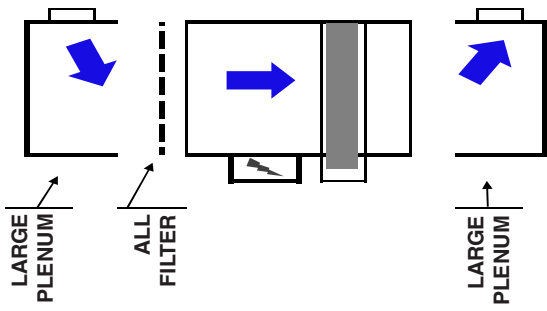

L-shaped

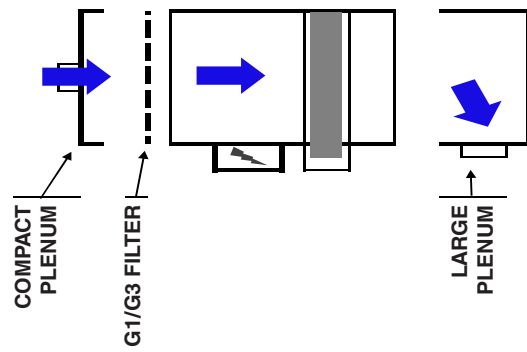

T-shaped

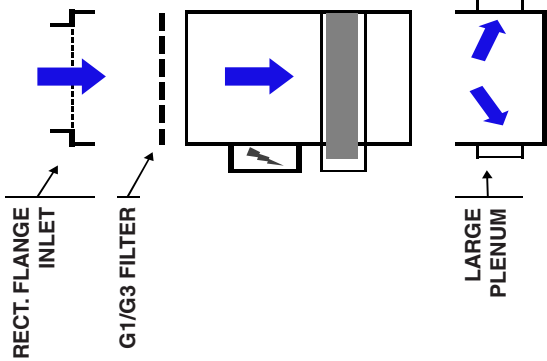

H-shaped or I-shaped

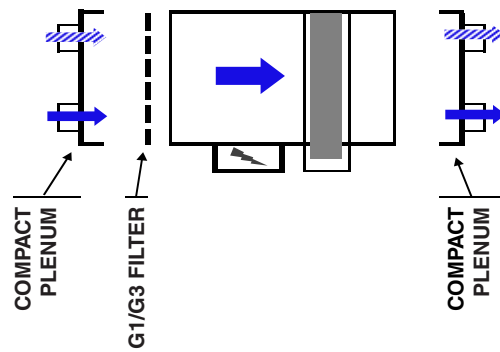

Without filter configurations (Ultra Compact Design)

U-shaped

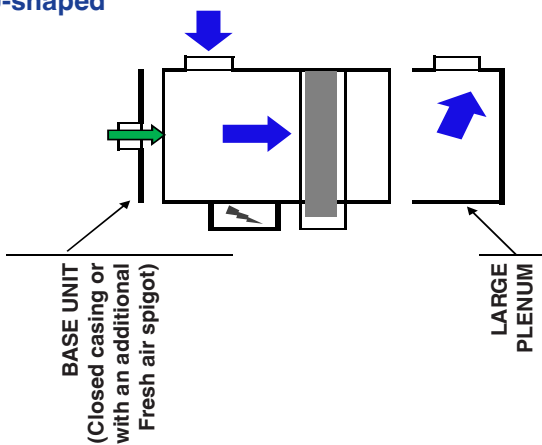

H-shaped or I-shaped

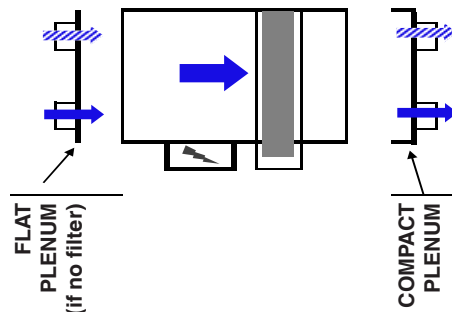

Compatibility Reminder	Size 2		Size 3	Sizes 4 to 7
	22x / 23x	279		
1x160	NH/NL	n.a.	n.a.	n.a.
1x200	NH/NL	NH	NH	n.a.
1x250	n.a.	n.a.	n.a.	n.a.

Compatibility Reminder	Size 2 to 3	Size 4	Size 5	Size 6	Size 7
2x160	NH/NL	n.a.	n.a.	n.a.	n.a.
2x200	NH/NL	NH/NL	NH	n.a.	n.a.
2x250	n.a.	n.a.	n.a.	NH	n.a.

n.a.: Not Available

Standard spigots configuration (Continued)

M5 Filter configurations

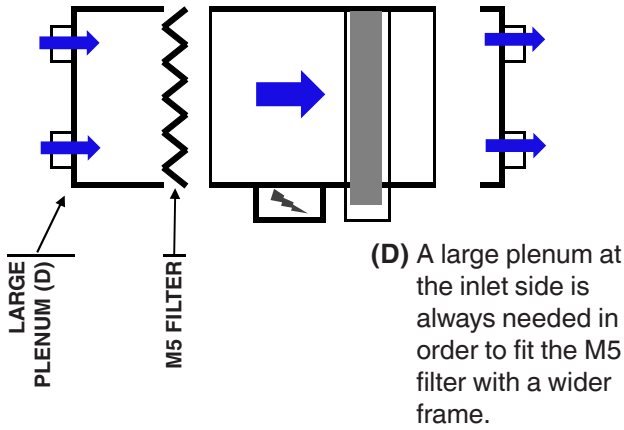

“Fresh Air” Configuration at outlet side

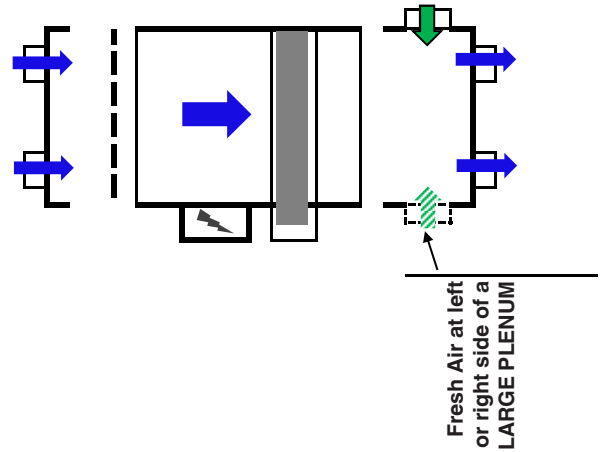

“Fresh Air” Configurations at inlet side

Lateral Fresh Air (opposite to coil hand)
Option 1 “Optimized”

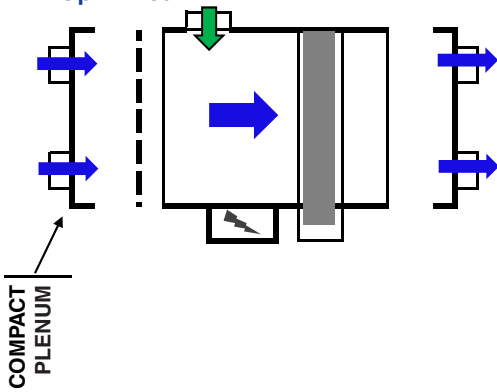

Inlet optimized: For compact design, the fresh air is fitted in base unit (opposite to coil hand).

Option 2 “In_opp”

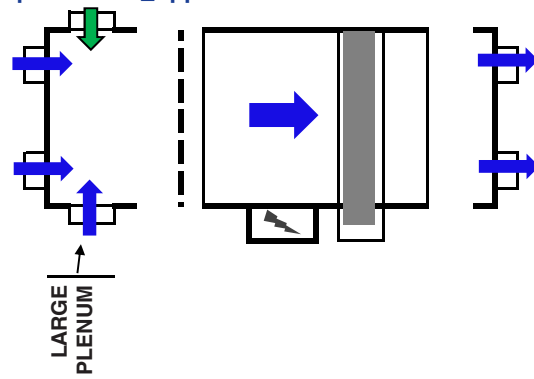

With this option, the fresh air position is opposite to coil hand and always fits into a large plenum.

Lateral Fresh Air “In_coil”

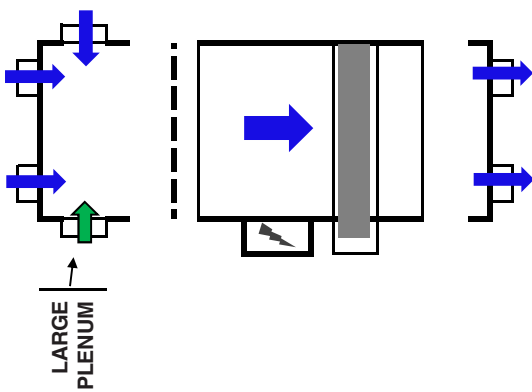

“In_line” Fresh Air (for sizes 2, 3 & 5)

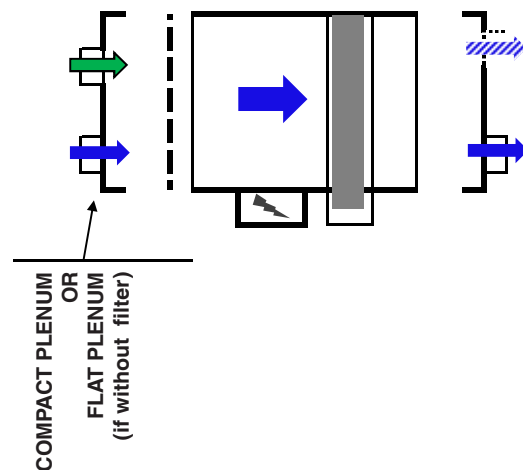

2 - DIMENSIONAL DRAWINGS

NOTE: All drawings shown have the coil connections on the right-hand side. Units with left-hand connections are symmetrical.

Standard unit with free air inlet and outlet

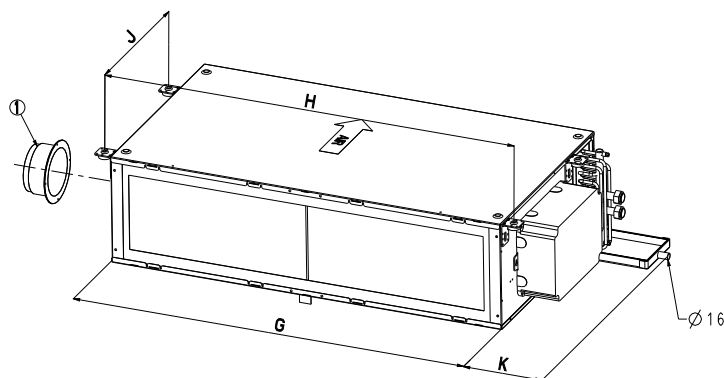
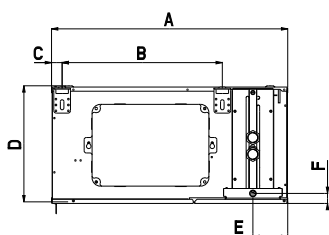

Dimensions in mm						
Size	2xx	3xx	4xx	5xx	6xx	7xx
A	520	520	520	520	575	575
B	330	330	330	330	385	385
C	25	25	25	25	25	25
D	235	235	235	235	285	285
E	85	85	85	85	85	85
F	17	17	17	17	25	25

Dimensions in mm						
Size	2xx	3xx	4xx	5xx	6xx	7xx
G	450	620	820	1020	1020	1320
H	500	670	870	1070	1070	1370
J	330	330	330	330	385	385
K	230	230	230	230	230	230
G + K	680	850	1050	1250	1250	1550
Weight* [kg]	15	18	23	27	30	36

Unit with rectangular flanges at air inlet and outlet

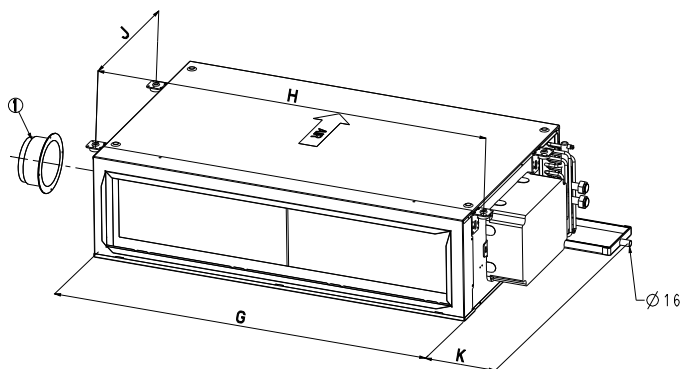
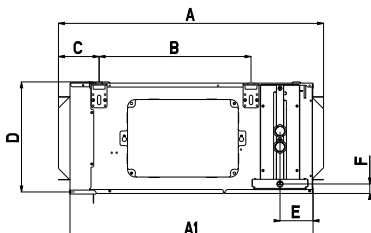

Dimensions in mm						
Size	2xx	3xx	4xx	5xx	6xx	7xx
A	615	615	615	615	670	670
B	330	330	330	330	385	385
C	103	103	103	103	103	103
D	235	235	235	235	285	285
E	85	85	85	85	85	85
Rectangular Flanges	380 x 160	550 x 160	750 x 160	950 x 160	950 x 210	1250 x 210

Dimensions in mm						
Size	2xx	3xx	4xx	5xx	6xx	7xx
F	17	17	17	17	25	25
A1	561	561	561	561	615	615
G	450	620	820	1020	1020	1320
H	500	670	870	1070	1070	1370
J	330	330	330	330	385	385
K	230	230	230	230	230	230
G + K	680	850	1050	1250	1250	1550
Weight* [kg]	15	18	23	27	30	36

LEGEND

- 1 Lateral optimized fresh air position in base unit (opposite to coil hand at inlet)
- * Maximum weight 42NL/NH (AC or EC motor version) - without valve option - without water

→ Air flow direction

All dimensions are in mm.

Unit without filter with compact plenum at air inlet and outlet (optimized lenght)

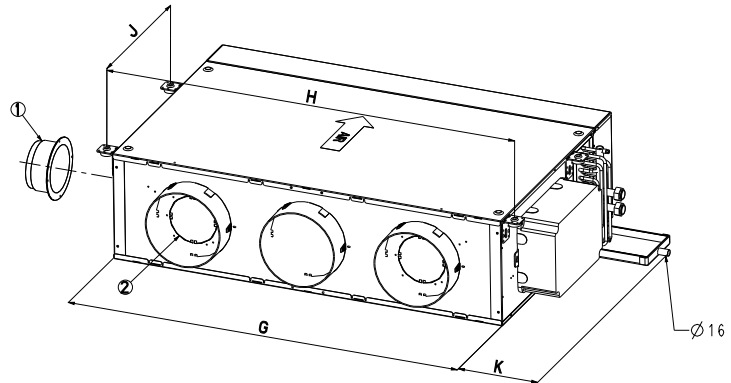
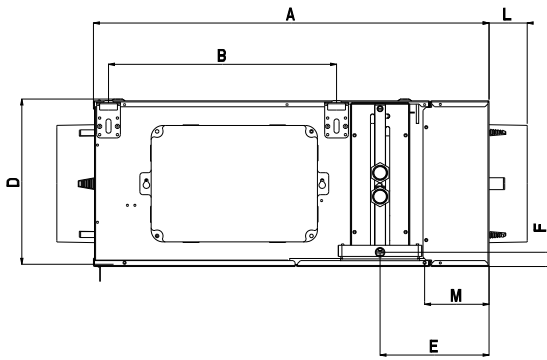

Dimensions in mm						
Size	2xx	3xx	4xx	5xx	6xx	7xx
A	611	611	611	611	666	666
B	330	330	330	330	385	385
C	25	25	25	25	25	25
D	235	235	235	235	285	285
E	185	185	185	185	185	185
F	17	17	17	17	25	25
G	450	620	820	1020	1020	1320

Dimensions in mm						
Size	2xx	3xx	4xx	5xx	6xx	7xx
H	500	670	870	1070	1070	1370
J	330	330	330	330	385	385
K	230	230	230	230	230	230
L	63	63	63	63	76	76
M	100	100	100	100	100	100
G + K	680	850	1050	1250	1250	1550
Weight* [kg]	19	23	29	33	37	44

Unit with G1 or G3 filter with compact plenum at air inlet and outlet

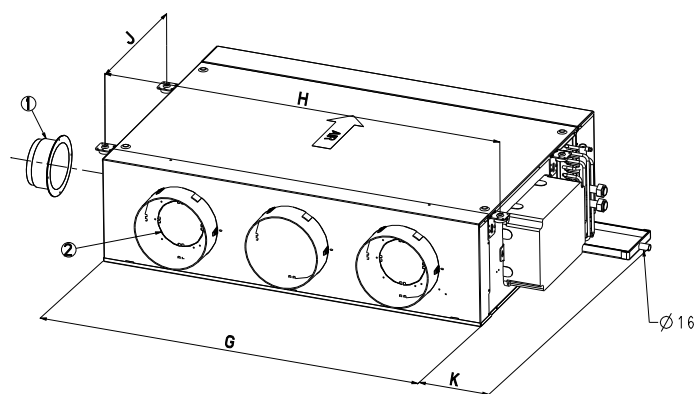
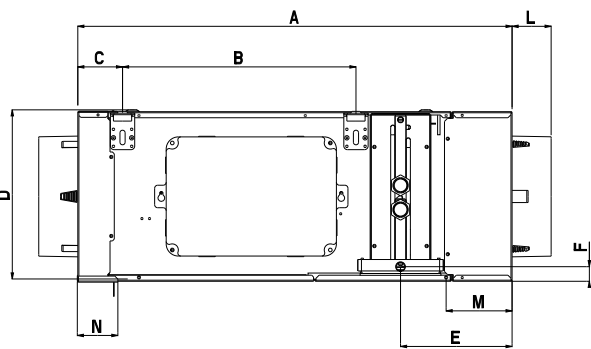

Dimensions in mm						
Size	2xx	3xx	4xx	5xx	6xx	7xx
A	660	660	660	660	715	715
B	330	330	330	330	385	385
C	75	75	75	75	75	75
D	235	235	235	235	285	285
E	185	185	185	185	185	185
F	17	17	17	17	25	25
G	450	620	820	1020	1020	1320

Dimensions in mm						
Size	2xx	3xx	4xx	5xx	6xx	7xx
H	500	670	870	1070	1070	1370
J	330	330	330	330	385	385
K	230	230	230	230	230	230
L	63	63	63	63	76	76
M	100	100	100	100	100	100
N	50	50	50	50	50	50
G + K	680	850	1050	1250	1250	1550
Weight* [kg]	19	23	29	33	37	44

LEGEND

- 1 Lateral optimized fresh air position in base unit (opposite to coil hand at inlet)
- 2 In line fresh air position for compact plenum (with or without filter)
- * Maximum weight 42NL/NH (AC or EC motor version) - without valve option - without water

→ Air flow direction

All dimensions are in mm.

Unit with G1, G3 or M5 filter with large plenum at air inlet and outlet

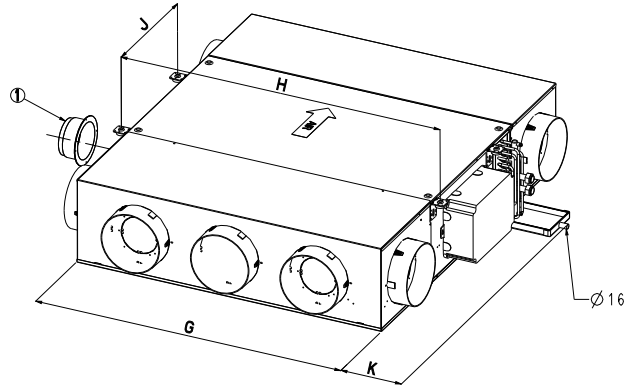
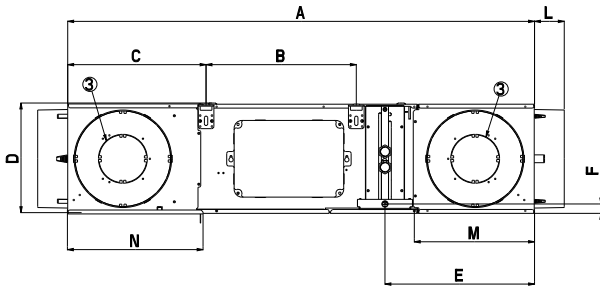

Dimensions in mm						
Size	2xx	3xx	4xx	5xx	6xx	7xx
A	1040	1040	1040	1040	1195	1195
B	330	330	330	330	385	385
C	305	305	305	305	355	355
D	235	235	235	235	285	285
E	333	333	333	333	382	382
F	17	17	17	17	25	25
G	450	620	820	1020	1020	1320

Dimensions in mm						
Size	2xx	3xx	4xx	5xx	6xx	7xx
H	500	670	870	1070	1070	1370
J	330	330	330	330	385	385
K	230	230	230	230	230	230
L	63	63	63	63	76	76
M	250	250	250	250	297	297
N	280	280	280	280	330	330
G + K	680	850	1050	1250	1250	1550
Weight* [kg]	22	27	34	40	45	53

LEGEND

- 1 Lateral optimized fresh air position in base unit (opposite to coil hand at inlet)
- 3 Lateral fresh air position in large plenum (at inlet or outlet side)
- * Maximum weight 42NL/NH (AC or EC motor version) - without valve option - without water

⇒ Air flow direction

All dimensions are in mm.

3 - MAIN MODULES AND COMPONENTS

3.1 - Casing

In order to further enhance occupant comfort this product range offers especially low noise levels. The casing is made of galvanised sheet steel with full high-efficiency internal lining for optimised thermal and sound insulation of the unit.

In order to comply with the various local regulations (fire class) the fan-coil unit is available with both class M1 type insulation (according to NF P 92-507) and Euroclass level B-s3-d0 (according to EN 13501). It is also equipped with anti-vibration mounts as standard.

In order to reduce the dimensions to the minimum, the units are equipped with high-efficiency heat exchangers with very high cooling capacity/treated air flow ratios. The condensate drain pan height is optimised.

3.2 - Fan motors

3.2.1 - Multi-speed fan motor assembly compliant with ErP 2015 regulation

Motor description

- Asynchronous motors, 4 poles with internal overload protection
- Permanent capacitor
- Class B winding insulation, varnish class F
- See operating limits in chapter 8.

The 42NH and 42NL have a multi-speed fan motor assembly with forward curved, double inlet, simple, double or triple wheel fans according to the unit size.

Five speeds are available as standard for 42NH (Six speeds for 42NL). Three speeds must be selected to allow connection of the fan motor in accordance with applicable electromechanical or electronic control.

- Minimum speed: R5 for 42NH; R6 for 42NL
- Maximum speed: R1
- Units can be supplied with Carrier electronic controls and prewired to a selection of three speeds.
- For other fan motor Speed wiring combinations refer to the unit options list (chapter 6).

3.2.2 - Low-consumption fan motor assembly (variable-speed LEC)

Motor description

- Permanent magnet brushless motor
- Electronically commutated
- Class B winding insulation, varnish class F
- See operating limits in chapter 8.

42NH and 42NL units are equipped with the variable-speed LEC fan motor, that is controlled by a 0 to 10 V signal, available with the Carrier NTC or WTC type electronic control.

NOTE: In this case the minimum control signal that allows motor start-up is 2 V for two- and four-pipe versions and 3 V for the versions equipped with electric heaters.

If the product is supplied without a Carrier control device, verification of EMC conformity is the responsibility of the installer.

3.3 - Fan wiring solutions

3.3.1 - Multi-speed unit with bare wires

As an option, all speeds of the multi-speed fan are available with bare wires (six speeds for 42NL and five speeds for 42NH) offering the unit greater flow control flexibility.

Minimum speed = R6 or R5, maximum speed = R1.

3.3.2 - Multi-speed unit with optional controller or electrical box (standard)

When ordering, three of the five speeds must be selected to allow connection of the fan motor in accordance with the applicable control (NTC, WTC or Electrical box for Carrier Thermostats).

With the electrical box, the installer can connect the unit to a terminal board. The electrical box can be opened with a screw driver.

The electrical box permits changing the speed wiring without access to the motor. All available speeds are connected.



Wiring example: By default R5 R3 R1 are connected on the terminal board.

Other 2 or 3 remaining speeds available, easy access

NOTE: The standard wiring for all ranges of units is always R5 R3 R1.

3.3.3 - Variable-speed low energy consumption (LEC) fan motor option with bare wires

The variable-speed low energy consumption (LEC) fan motor must be controlled by a 0-10 V d.c. signal.

3.3.4 - Variable-speed low energy consumption (LEC) fan motor with electrical box (standard)

This option allows the installer to connect the unit to a terminal board inside an electrical box. The electrical box can be opened with a screw driver.

The 0-10 V d.c. signal that controls the variable fan speed is directly accessible at the terminal board.

3.3.5 - Cover only option

An accessory plastic cover can be provided for a control supplied by the customer (max. dimensions L = 200 mm x D = 100 mm x H = 95 mm) and is installed on site or at the factory on a multi-speed unit or a variable-speed low energy consumption (LEC) fan motor.

NOTE: This option is not compatible with the electrical box option.

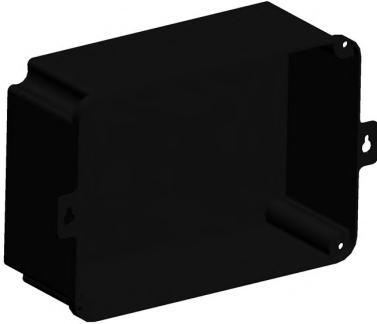

3.3.6 - Fuse holder option

A fuse holder can be provided as an option for all controllers or with the electrical box.

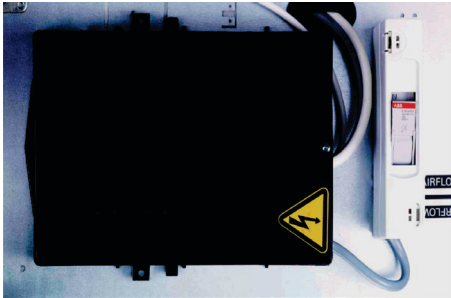

3.4 - Water coil

- Aluminium fins mechanically bonded by expansion onto copper tubes
- 1/2" threaded water inlet and outlet connections (female) for sizes 2 to 5
- 3/4" threaded water inlet and outlet connections (female) for sizes 6 and 7
- Air purge valves and drain are standard.
- Service pressure 1550 kPa.

The coil is integral with the drain pan and coil access door to ease of removal during service and maintenance.

3.5 - One-piece condensate drain pan

Insulated drain pan with a 16 mm external drain connection diameter and fire rating M1 (according to NFP 92-507).

3.6 - Filter

3.6.1 - Specifications

The 42NH and 42NH include as standard a non regenerable G1 filter according to EN 779.

A G3 filter and a pleated M5 filter (for range 42NH only) according to EN 779 are also available. G3 and M5 filters have medium fire rating M1 (according to NFP 92-507) and a metal frame.

The "without filter" option is only available for units with a plenum or a rectangular flange at the air inlet side to ensure that a ductwork will be connected when the unit operates.

To prevent coil soiling, Carrier recommends the usage of a filter either fitted in the fan-coil unit or in return air grille.

42NH offers four filters configurations:

- Without filter: only available for units with an inlet plenum with spigots or with a rectangular flange inlet
- G1 filter: supplied as standard
- G3 filter: metal wire frame, medium efficiency
- M5 filter (only for 42NH): metal wire frame, high efficiency, thickness = 55 mm.

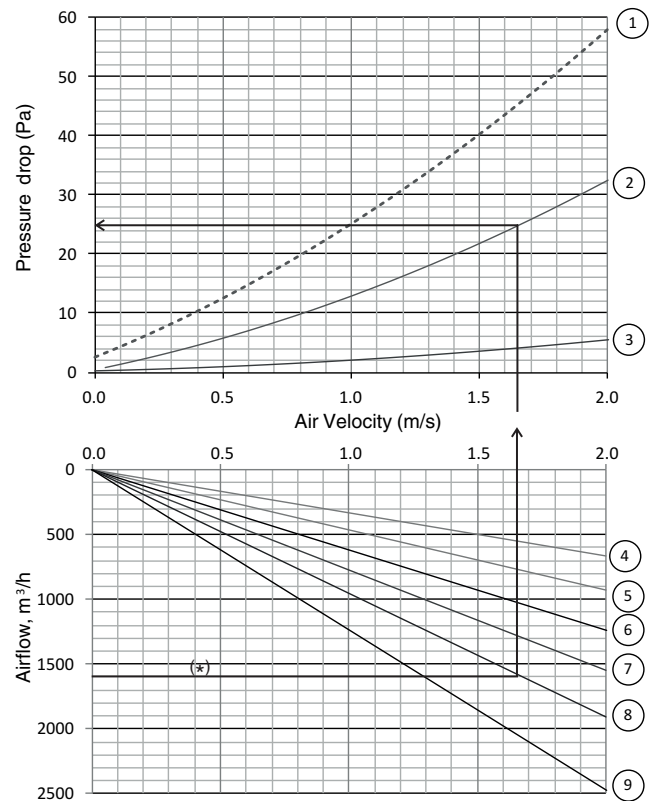

Legend

- 1 M5 filter
- 2 G3 filter
- 3 G1 filter
- 4 Airflow for 42NH/NL Size 2
- 5 Airflow for 42NH/NL Size 3
- 6 Airflow for 42NH/NL Size 4
- 7 Airflow for 42NH/NL Size 5
- 8 Airflow for 42NH/NL Size 6
- 9 Airflow for 42NH/NL Size 7

(*) Example: The pressure drop of a G3 filter used in a 42NH645 is 25Pa for a 1600 m³/h airflow.

3.6.2 - Filter access

Without rectangular flange inlet, the filter removal is from the rear.

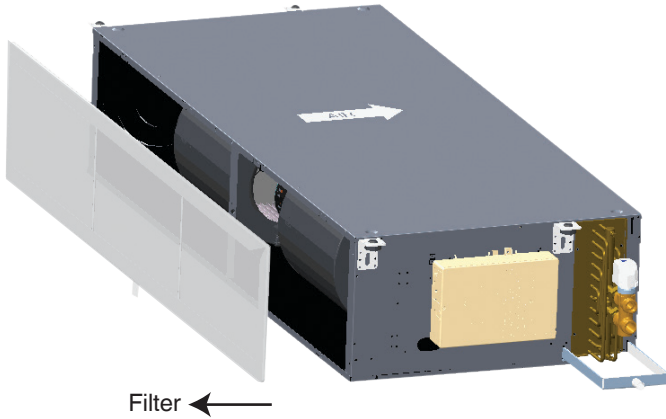

With rectangular flange inlet or plenums, the filter removal is from below (trapdoor).

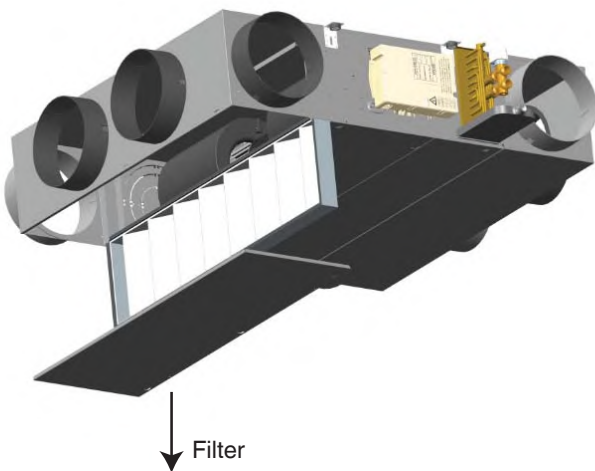
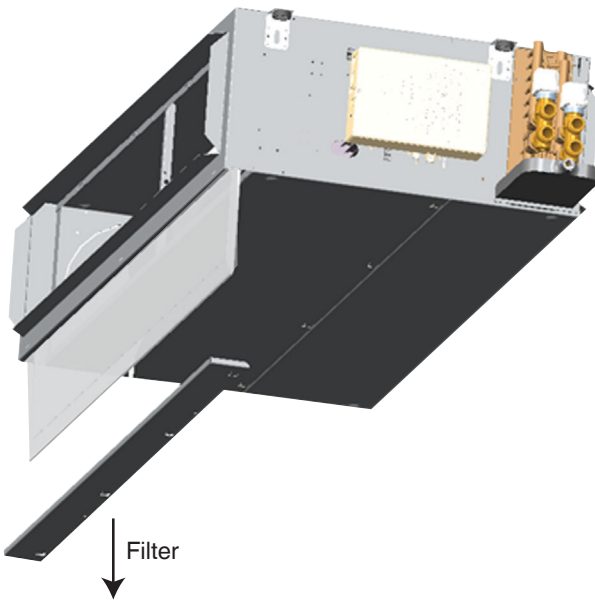

4 - OPTIONS SPECIFICATIONS

4.1 - Electric heater (option for 2-pipe coil)

Electric heater-resistance wire type

- Supply voltage: 230 V - 1 ph - 50 Hz
- Heater size and capacity per unit (+5% ; -10%):

Electrical Heater Capacity	Low	Medium	High	Very High
42NH/NL 2-5	1 x 500 W	1 x 800 W	1 x 1000 W	NA
42NH/NL 2-9	1 x 500 W	1 x 800 W	1 x 1000 W	NA
42NH/NL 3-5	1 x 500 W	1 x 800 W	1 x 1000 W	1 x 1600 W
42NH/NL 3-9	1 x 500 W	1 x 800 W	1 x 1000 W	1 x 1600 W
42NH/NL 4-5	2 x 500 W	2 x 800 W	2 x 1000 W	NA
42NH/NL 4-9	1 x 500 W	1 x 800 W	1 x 1000 W	1 x 1600 W
42NH/NL 5-5	2 x 500 W	2 x 800 W	2 x 1000 W	NA
42NH/NL 5-9	2 x 500 W	2 x 800 W	2 x 1000 W	NA
42NH 6-5	2 x 500 W	2 x 800 W	2 x 1000 W	2 x 1600 W
42NH 6-9	2 x 500 W	2 x 800 W	2 x 1000 W	2 x 1600 W
42NH 7-5	2 x 500 W	2 x 800 W	2 x 1000 W	2 x 1600 W
42NH 7-9	2 x 500 W	3 x 500 W	3 x 800 W	3 x 1000 W

- The heater is protected with a dual safety device:
 - a) Self-holding automatically reset integrated safety thermostat
 - b) Destructive thermofuse link
- Available for 2-pipe coil only.

WARNING: Minimum air flow must be maintained to avoid damaging the electric heaters.

A minimum control signal of 3V is selected by default with Electronic Carrier controller (NTC / WTC). To prevent low airflow with 42NL range, plenum cannot be chosen as an option.

4.2 - Fresh air controller (option)

4.2.1 - Constant volume fresh air controller

The fan coil can be fitted with a constant fresh air flow controller adjustable from 15 m³/h to 180 m³/h to allow control of the introduction of fresh air and of the air change rate.

The fresh air supply can be located in the air supply plenum, in the air return plenum or in the side of the base unit casing for compact design.



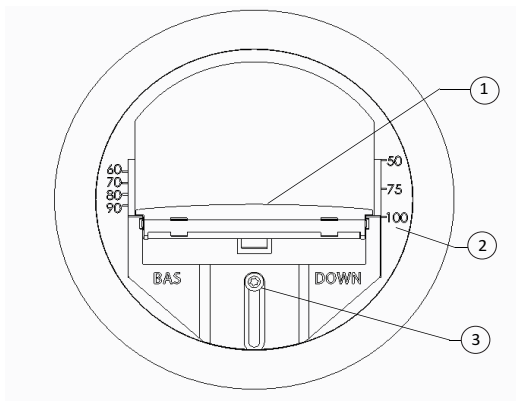

Example: Range 50-100 m³/h

- 1 Air Damper
- 2 Fresh airflow damper position setting (in m³/h)
- 3 Airflow adjustment screw

The fresh air controller may be modified on site by relocating the damper (adjustable screw). Three ranges of air-controller are provided: 15 to 50m³/h, 60 to 100m³/h and 110 to 180m³/h.

IMPORTANT: If an optional return air temperature sensor is provided, the constant fresh air flow rate must not exceed 50% of the unit supply air flow rate at minimum speed.

NOTE: To operate correctly, the fresh air flow controller requires a differential pressure in the range of 60 Pa to 210 Pa.

4.2.2 - Variable volume fresh air controller

The unit can be equipped with an optional variable fresh air flow controller from 0-55 l/s (0-200 m³/h). It is connected to the numeric Carrier controller and can regulate the fresh air intake in two ways:

- Either using a fixed rate set by the installer that can be reconfigured as required
- Or based on the CO₂ level; in this case it is connected to a CO₂ sensor via the Carrier numeric controller.



NOTE: With the variable fresh air flow controller the upstream pressure in the fresh air duct must be 180 Pa.

4.3 - Valves and actuators (option)

NOTE: The motor valve assembly is normally closed.

4.3.1 - Valve actuators

A wide choice of actuators is available with two or four-way valve bodies (three-way with integral bypass) to offer the right solution for any controller type and customer requirement, from on/off to proportional types, with either 230 V or 24 V power supply:

- On/off 230 V actuator
- On/off 24 V actuator
- Floating 3-point 230 V actuator
- Floating 3-point 24 V actuator
- Modulating 0-10 V/24 V actuator

When combined with LEC motors and WTC or NTC controllers, floating 3-point 230-V actuators are recommended to increase energy savings and enhance comfort.

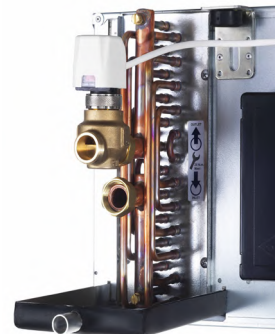
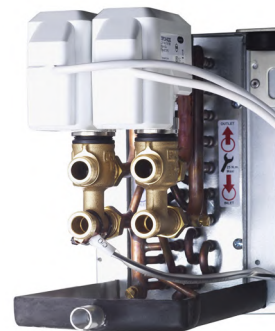

NOTE: 24V power supply actuators are not compatible with Carrier controllers (Thermostats A/B/C/D, WTC & NTC).

4.3.2 - Standard two-way valve body and three-way valve body (with integral bypass)

Features of the 1/2" two-way and three-way valves for 42NL/NH sizes 2 to 5

- 1/2" male BSP connection for union nuts
- Straight valve body with arrow indicating direction of flow embossed on valve body
- Nominal size DN15 for 1/2" valve
- Nominal pressure: PN 16 bar

Features of the 3/4" two-way and three-way valves for 42NH sizes 6 and 7

- 3/4" male BSP connection for union nuts
- Straight valve body with arrow indicating direction of flow embossed on valve body
- Nominal size DN20 for 3/4" valve
- Nominal pressure: PN 16 bar

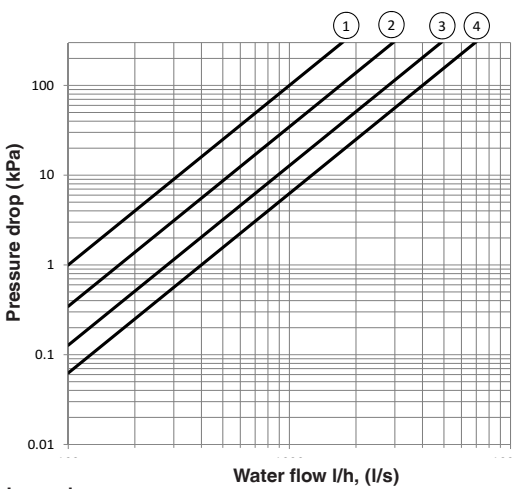

Legend

- 1 1/2" - ON/OFF valve 42NL/NH - Size 2 Kvs = 1
- 2 1/2" - ON/OFF valve 42NL/NH - Sizes 3, 4, 5 Kvs = 1.7
- 3 3/4" - ON/OFF valve 42NL/NH - Size 6 Kvs = 2.8
- 4 3/4" - ON/OFF valve 42NL/NH - Size 7 Kvs = 4

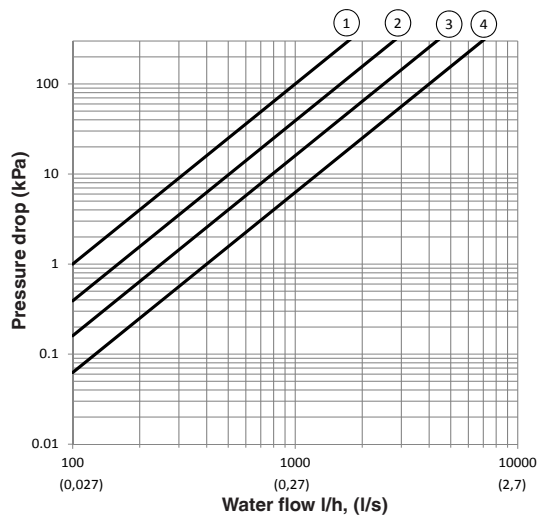

Legend

- 1 1/2" - Modulating valve (3-points & 0-10V) 42NL/NH - Size 2 Kvs = 1
- 2 1/2" - Modulating valve (3-points & 0-10V) 42NL/NH - Sizes 3, 4, 5 Kvs = 1.6
- 3 3/4" - Modulating valve (3-points & 0-10V) 42NL/NH - Size 6 Kvs = 2.5
- 4 3/4" - Modulating valve (3-points & 0-10V) 42NL/NH - Size 7 Kvs = 4

4.3.3 - Two way balancing valve body

New two-way valves with embedded balancing function technology are available as an option with 42NH and 42NL units. The Carrier two-way valve with balancing function combines the functionality of a dynamic balancing valve and a control valve in one product. They are available as an option with Carrier NTC and WTC controllers.



The dynamic balancing function maintains a constant differential pressure over the control valve. The control valve regulates the flow by means of a variable orifice which is controlled by the actuator.

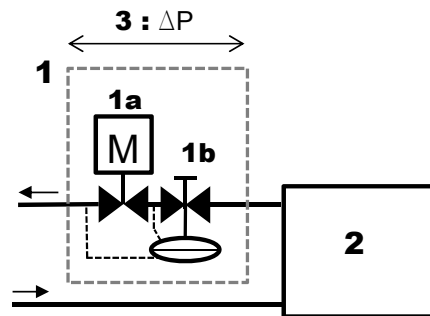

Legend

1. Two-way valve with balancing function
 - 1a. Valve actuator for waterflow control
 - 1b. Differential pressure controller & balancing feature
2. Fan-coil unit
3. Minimum operating pressure drop at nominal waterflow:
 - 15 kPa for sizes 2 & 3
 - 20 kPa for sizes 4 & 5

The constant differential pressure across the control valve ensures accurate control and maximizes valve authority, independently of the pressure conditions in the system.

Advantages versus standard two-way valve

- Improved and reliable commissioning. The water flow can be set and controlled on site.
- Higher energy efficiency due to optimal waterflow and maximized valve authority.
- Enhanced comfort thanks to stable and precise ambient temperature control.

Features of the 3/4" two-way valves with balancing function for 42NL/NH sizes 2 and 3

- 3/4" male BSP connection for union nuts
- Straight valve body with arrow indicating direction of flow embossed on valve body
- Nominal size DN 15 for 3/4" valve
- Nominal pressure: PN 16 bar
- Minimum operating differential pressure = 15 kPa at nominal flow.

Features of the 1" two-way valves with balancing function for 42NL/NH sizes 3 and 4

- 1" male BSP connection for union nuts
- Straight valve body with arrow indicating direction of flow embossed on valve body
- Nominal size DN 20 for 1" valve
- Nominal pressure: PN 16 bar
- Minimum operating differential pressure = 20 kPa at nominal flow.

As a secondary option, two pressure points can be added to the valve body in order to measure precisely the waterflow during the commissioning and the maintenance stages.

4.4 - Flexible water pipes (option)

4.4.1 - Materials

- Pipes: MEPD-based elastomer (modified ethylene-propylene-diene)
- Braid: 304L stainless steel
- Insulation: cellular foam rubber with M1 fire rating (9 mm thick, flexible water pipes).

4.4.2 - Characteristics

- Minimum bend radius (insulated pipes): 106 mm
- The flexible water pipes are designed for treated or untreated water.
- Maximum operating pressure: 16 bar
- 1/2" female flat gas connections for sizes 2, 3, 4 and 5
- 3/4" female flat gas connections for sizes 6 and 7
- Length: 1 m.

4.5 - Sensors (option)

4.5.1 - Water sensor

A water temperature sensor can be provided as an option for NTC and WTC controllers.

- For 2-pipe coil: The sensor is installed on a cooling/heating water pipe (for change-over function).
- For 4-pipe coil: The sensor is installed on a heating water pipe (for cold-draft function that prevents the operation of the unit when the heating network is off).

In case of fan-coil unit delivered with an electrical box, the "water sensor" option is actually a switch that will be connected to the Carrier thermostat.

NOTE:

- *The water sensor option (switch) with electrical box is only available for 2-pipe coil without electrical heater.*
- *A water probe can also be provided as an accessory only in order to use the cold draft function of the thermostat.*

4.5.2 - Air sensor

Two air sensors, factory fitted, are available as an option for NTC and WTC controllers. They measure the air temperature at the inlet and/or at the outlet side.

4.5.3 - CO₂ sensor

For indoor air quality control, a CO₂ sensor is available as an option for NTC and WTC controllers. The sensor is factory fitted at the inlet side.

4.6 - Condensate pump (option)

The condensate pump option is designed to fit on the side of the unit drain pan. Electrical power supply 230V-50/60Hz.

Condensate pump discharge performances:

TABLE OF ACTUAL DISCHARGE (l/h)				
Discharge head (B)	Total length of pipe (Ø int. 6 mm) A			
	5 m	10 m	20 m	30 m
0 m	20	19	18	17
2 m	16	15	14	13.5
4 m	11.5	11	10.5	10
6 m		8.5	7.5	6.5
8 m		6	5	4
10 m		4	3.5	2.5

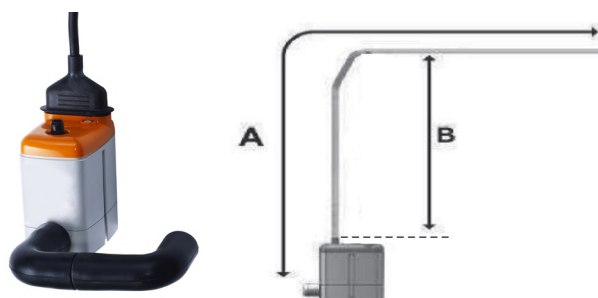

5 - CONTROL (OPTION)

The unit can be supplied with a wide range of Carrier controls. These offer functions to suit the various application requirements, summarised in the table below.

	Thermostats	NTC	WTC
Communication Protocols			
Carrier Communication Network (CCN) Aquasmart compatible		x	
BACnet MSTP			x
LON			x
Control algorithms			
On-off	x		
Proportional-integral		x	x
Carrier Energy saving algorithm		x	x
Fan control			
AC motors 3 speeds descreet	Type A&B	x	x
Automatic optimum fan speed selection	x	x	x
EC motors 3 speeds descreet	Type C&D	x	x
EC motors Variable speed		x	x
Water Valve management			
Air flow control only (no water valve)	x		
230V On-off actuators	x	x	x
230V Modulating actuators (floating 3pts)		x	x
Main functions			
Setpoint control	x	x	x
Occupied/unoccupied mode	x	x	x
Frost protection mode	x	x	x
Window / Door contact input	x	x	x
Measurement of water inlet temperature for automatic seasonal changeover (2 pipes)	Type A&C	x	x
Measurement of water inlet temperature to prevent cold-draft (4 pipes and 2 pipes + electric heater)	Type B&D	x	x
Manual changeover	x	x	x
Frost protection mode	x	x	x
Continuous ventilation within dead-band	x	x	x
Periodical ventilation within dead-band	x	x	x
On-site configuration	x	x	x
Unit grouping Master/Slave	x	x	x
Cassette Louvers control		x	x
Supply air temperature monitoring limiting		x	x
Electrical heater loadshed		x	x
Dirty filter alarm		x	x
Alarm reporting		x	x
Indoor Air Quality control (CO ₂ sensor)		o	o
Demand control ventilation (DCV) (0-10V fresh air valve)		o	o
Free cooling mode			o
Presence detection			o
User interfaces			
Automatic or manual fan speed control	x	x	x
Setpoint adjustment	x	x	x
Occupancy (eco) button	x	x	o
Digital display		o	o
Remote control (infra-red)		o	o
CO ₂ sensor		o	o
Luminosity sensor			o
Motion detection			o
Easy connection RJ45 jack (on wall mounted UI)			x
Light & Blinds management			
Light power modules			o
Blinds power modules			o
Control kit			
On site control kit solution			o

Legend

- X Feature available as standard
- O Optional

NOTE: For the features and specifications of the Carrier controllers refer to the technical documentation for each controller.

Upon special request other controller types can be factory-installed on the units (supplied by Carrier or the customer).

6 - PRODUCT CHARACTERISTICS LIST

Characteristic Name	Digit n° Codification	Value	Description	Pack.	Compatibility		
Range	1-2	42					
	3-4	NH					
		NL					
UNIT SIZE (Digits 5 - 6 - 7)	Chassis size	5	2	Chassis Size 2	Yes	Unit size availability (Digit n° 5-6-7):	
			3	Chassis Size 3		2-pipe:	
			4	Chassis Size 4		4-pipe:	
			5	Chassis Size 5		NL / NH 225;235;229;239;279	NL / NH 235;239;279
			6	Chassis Size 6		NL / NH 325;335;329;339	NL / NH 335;339
			7	Chassis Size 7		NL / NH 425;435;429;439	NL / NH 435;439
	Efficiency	6	2	Standard efficiency	Yes	NL / NH 525;535;529;539	NL / NH 535;545;539;549
			3	Medium efficiency		NH 635;645;639;649	NH 645;649
			4	High efficiency		NH 735;745;739;749	NH 735;745;739;749
			7	Extra High efficiency			
	Fan type	7	5	AC multispeed motor	Yes		
			9	EC low consumption motor			
Coil hand & type	8	F	2 pipes coil Left Hand	Yes			
		G	2 pipes coil Right Hand				
		C	4 pipes coil Left Hand				
		D	4 pipes coil Right Hand				
Control	9	-	Bare wires	Yes	Valves and actuators must be selected with NTC		
		E	Electrical Box				
		K	NTC				
		L	WTC LON				
		M	WTC BACNET				
Valve body	10	-	Without valve	Yes	Balancing valves are not available for unit sizes 6xx and 7xx		
		G	2-way valve	Yes			
		H	4-way valve	Yes			
		L	2-way balancing valve	No			
		T	2-way balancing valve and pressure points	No			
Electrical heater	11	-	Without electric heater	Yes	Electrical heaters are not compatible with 42NL with plenum.		
		E	500W electric heater		Highest capacity for unit size 2xx		
		F	800W electric heater		Highest capacity for unit sizes 3xx and 4x9		
		G	1000W electric heater		Highest capacity for unit sizes 4x5 and 5xx		
		H	1500W electric heater		Highest capacity for unit sizes 7x9		
		J	1600W electric heater		Highest capacity for unit sizes 6xx and 7x5		
		K	2000W electric heater				
		L	2400W electric heater				
		N	3200W electric heater				
Valve actuator	12	-	Without actuator	Yes	24V actuators are not available with Carrier controllers 3 points floating actuators are not available with Electrical Box		
		A	230V ON/OFF actuator	Yes			
		C	230V floating actuator (3 points)	No			
		B	24V ON/OFF actuator	Yes			
		D	24V floating actuator (3 points)	No			
		E	24V 0-10V modulating actuator	No			
Rectangular flanges	13	-	Without rectangular flange	Yes			
		A	Outlet rectangular flange only	Yes			
		B	Inlet rectangular flange only	Yes			
		C	Inlet and outlet rectangular flanges	Yes			
Specific (options selection)	14	-	Without specific option	Yes			
		A	With specific options (factory fitted)	Yes			

Legend:

Default value for mandatory characteristic

Pack: Available with individual packaging

6 - PRODUCT CHARACTERISTICS LIST (CONT.)

Specific options (can be selected if digit n°14 = A*)

Characteristic Name	Value	Description	Pack.	Compatibility
Indoor air quality	Without	Filter	Yes	Only available with rect. flanges or plenum
	G1		Yes	
	G3		Yes	
	M5		No	
Fan speed wiring for AC motor	654	AC motor speeds arrangement: R6 = minimum speed for 42NL R5 = minimum speed for 42NH R1 = maximum speed When this option is not selected, the standard wiring for all 42NL and 42NH units is always R5-R3-R1	Yes	R6 not available for 42NH range
	653			
	652			
	651			
	643			
	642			
	641			
	632			
	631			
	621			
	543			
	542			
	541			
	532			
	531			
521				
432				
431				
421				
321				
Packaging	Bundle	Filmed on a pallet (shrink wrap)	-	
	Individual	Individual packaging		
Inlet plenum	1_inline	1 spigot in line	No	According to unit sizes, filter and fresh air position Use selection software for more informations
	1_lat_op	1 lateral spigot opposite to coil side		
	1_lat	1 lateral spigot at coil side		
	2	2 spigots		
	2_lat	2 lateral spigots		
	3	3 spigots		
	4	4 spigots		
	5	5 spigots		
Outlet plenum	6	6 spigots	No	According to unit sizes, filter and fresh air position Use selection software for more informations
	7	7 spigots		
	1_inline	1 spigot in line		
	1_lat_op	1 lateral spigot opposite to coil side		
	1_lat	1 lateral spigot at coil side		
	2	2 spigots		
	2_lat	2 lateral spigots		
Inlet spigots diameter	DN160	Spigot diameter	No	DN160 Not available for unit sizes 6xx to 7xx DN250 Not available for unit sizes 2xx to 5xx
	DN200			
	DN250			
Outlet spigots diameter	DN160	Spigot diameter	No	DN160 Not available for unit sizes 6xx to 7xx DN250 Not available for unit sizes 2xx to 5xx
	DN200			
	DN250			
Fresh air	DN125	Without controller - spigot only	No	Motorized air damper compatible with NTC and WTC only (Position feedback is not available if WTC and CO ₂ sensor are also selected)
	DN125_15_50	15 to 50 m ³ /h controller		
	DN125_50_100	50 to 100 m ³ /h controller		
	DN125_100_180	100 to 180 m ³ /h controller		
	Adaptor_D125	For motorized air damper (to be ordered separately)		
Fresh air position	In_opp	At inlet side opposite to coil hand	No	According to unit sizes, filter and spigots selection Use selection software for more informations
	In_coil	At inlet side same as coil hand		
	In_line	At inlet rear side		
	Optimized	Inlet optimized: opposite to coil hand in base unit for compact design		
	Out_opp	At outlet side opposite to coil hand		
	Out_coil	At outlet side same as coil hand		
Fuse holder	boolean	Fuse holder	Yes	
Plastic cover	boolean	Plastic cover	Yes	For bare wires (without control only)
Condensate pump	boolean	Condensate pump	No	
Flexible	boolean	Flexible hoses	No	
Return air sensor	boolean	Return air temperature sensor	Yes	Compatible with NTC and WTC only
Supply air sensor	boolean	Supply air temperature sensor	Yes	Compatible with NTC and WTC only
Water temperature sensor	boolean	Water temperature sensor	Yes	According to controller and coil type
CO ₂ sensor	boolean	CO ₂ sensor	Yes	Compatible with NTC and WTC only

Legend:

Default value for mandatory characteristic

Pack: Available with individual packaging

* If Digit n°14 = "-" then default values are selected.

Boolean: yes or no

7 - 42NH AND 42NL PERFORMANCE DATA

7.1 - Physical and electrical data at Eurovent conditions - 42NL - Sizes 2 and 3

With G1 filter - without plenum

42NL	225						235						229				239			
Fan speed (Eurovent certification speeds)	R6 (L)	R5 (M)	R4 (H)	R3	R2	R1 (Max)	R6 (L)	R5 (M)	R4 (H)	R3	R2	R1 (Max)	2V (L)	4V (M)	6V (H)	10V (Max)	2V (L)	5V (M)	7V (H)	10V (Max)
Air flow	59	69	96	109	125	138	59	69	96	109	125	138	43	58	73	102	43	65	81	102
Available static pressure	214	248	346	393	449	497	214	248	346	393	449	497	153	210	261	368	153	234	292	368
Available static pressure	0	0	0	0	0	0	0	0	0	0	0	0	0	0	0	0	0	0	0	0
Cooling mode, two pipes*																				
Total cooling capacity	1.20	1.36	1.77	1.93	2.10	2.22	1.39	1.58	2.09	2.31	2.53	2.71	0.89	1.18	1.42	1.85	1.02	1.50	1.82	2.19
Sensible cooling capacity	0.96	1.10	1.45	1.60	1.76	1.88	1.06	1.22	1.64	1.82	2.03	2.19	0.71	0.95	1.15	1.52	0.77	1.15	1.41	1.73
Water flow rate	0.06	0.06	0.08	0.09	0.10	0.11	0.07	0.08	0.10	0.11	0.12	0.13	0.04	0.06	0.07	0.09	0.05	0.07	0.09	0.11
Water pressure drop	210	230	300	330	360	380	240	270	360	400	440	470	150	200	240	320	170	260	310	380
Water pressure drop	15	19	31	36	41	45	11	15	26	30	35	40	8	15	21	33	6	13	20	28
Water content	0.4						0.5						0.4				0.5			
Heating mode, two pipes**																				
Heating capacity	1.69	1.92	2.51	2.76	3.03	3.23	1.86	2.13	2.85	3.16	3.51	3.78	1.25	1.66	2.01	2.64	1.36	2.02	2.46	3.00
Cooling mode, four pipes*																				
Total cooling capacity							1.05	1.19	1.56	1.71	1.87	1.99					0.78	1.14	1.37	1.63
Sensible cooling capacity							0.90	1.02	1.35	1.49	1.65	1.77					0.66	0.97	1.18	1.42
Water flow rate							0.05	0.06	0.08	0.08	0.09	0.09					0.04	0.06	0.07	0.08
Water pressure drop							180	210	270	290	320	340					130	200	240	280
Water pressure drop							4	6	10	11	14	15					2	5	7	10
Water content							0.3										0.3			
Heating mode, four pipes***																				
Heating capacity							1.87	2.11	2.70	2.94	3.17	3.34					1.40	2.02	2.40	2.82
Water flow rate							0.04	0.05	0.07	0.07	0.08	0.08					0.03	0.05	0.06	0.07
Water pressure drop							160	190	240	260	280	290					120	180	210	250
Water pressure drop							5	6	9	11	12	13					3	5	7	10
Water content							0.2										0.2			
Electric heater	230V ±10% - 1ph						230V ±10% - 1ph						230V ±10% - 1ph				230V ±10% - 1ph			
Maximum capacity	1000						1000						1000				1000			
Current drawn	4.6						4.6						4.6				4.6			
Sound levels																				
Sound power level (global)	38	41	48	51	54	57	38	41	48	51	54	57	32	37	39	48	32	38	41	48
Electrical data, motor																				
Power input	28	31	45	54	65	80	28	31	45	54	65	80	3	5	7	13	3	5	9	13
Current drawn	0.14	0.17	0.20	0.23	0.28	0.35	0.14	0.17	0.20	0.23	0.28	0.35	0.05	0.06	0.08	0.14	0.05	0.06	0.10	0.14
FCEER [energy class] - 2 pipes	43	[E]					50	[E]					264	[A]			309	[A]		
FCCOP [energy class]	60	[E]					67	[E]					376	[A]			416	[A]		
FCEER [energy class] - 4 pipes							32	[E]									235	[A]		
FCCOP [energy class]							67	[E]									422	[A]		

42NL	325						335						329				339			
Fan speed (Eurovent certification speeds)	R6 (L)	R5 (M)	R4 (H)	R3	R2	R1 (Max)	R6 (L)	R5 (M)	R4 (H)	R3	R2	R1 (Max)	2V (L)	4V (M)	6V (H)	10V (Max)	2V (L)	4V (M)	6V (H)	10V (Max)
Air flow	84	94	124	144	154	168	84	94	124	144	154	168	55	88	120	165	55	88	120	165
Available static pressure	302	338	447	517	555	606	302	338	447	517	555	606	198	318	431	594	198	318	431	594
Available static pressure	0	0	0	0	0	0	0	0	0	0	0	0	0	0	0	0	0	0	0	0
Cooling mode, two pipes*																				
Total cooling capacity	1.47	1.60	1.97	2.19	2.29	2.43	1.80	1.99	2.54	2.88	3.04	3.26	1.06	1.53	1.92	2.40	1.22	1.89	2.46	3.22
Sensible cooling capacity	1.25	1.37	1.71	1.92	2.03	2.16	1.42	1.58	2.04	2.32	2.47	2.66	0.88	1.31	1.67	2.13	0.96	1.50	1.97	2.62
Water flow rate	0.07	0.08	0.09	0.11	0.11	0.12	0.09	0.09	0.12	0.14	0.14	0.16	0.05	0.07	0.09	0.11	0.06	0.09	0.12	0.15
Water pressure drop	250	280	340	380	390	420	310	340	440	490	520	560	180	260	330	410	210	320	420	550
Water pressure drop	10	11	17	20	22	25	11	13	21	27	29	33	5	10	16	24	5	12	20	32
Water content	0.7						0.9						0.7				0.9			
Heating mode, two pipes**																				
Heating capacity	2.25	2.46	3.04	3.36	3.51	3.71	2.60	2.89	3.68	4.14	4.37	4.67	1.58	2.35	2.95	3.67	1.76	2.73	3.56	4.61
Cooling mode, four pipes*																				
Total cooling capacity							1.79	1.96	2.42	2.68	2.82	2.99					1.27	1.87	2.36	2.95
Sensible cooling capacity							1.41	1.55	1.95	2.18	2.30	2.46					0.98	1.47	1.89	2.43
Water flow rate							0.09	0.09	0.12	0.13	0.13	0.14					0.06	0.09	0.11	0.14
Water pressure drop							310	340	420	460	480	510					220	320	400	510
Water pressure drop							15	18	26	31	34	37					8	16	25	37
Water content							0.6										0.598			
Heating mode, four pipes***																				
Heating capacity							2.78	3.03	3.66	3.98	4.13	4.32					1.95	2.90	3.58	4.27
Water flow rate							0.07	0.08	0.09	0.10	0.10	0.11					0.05	0.07	0.09	0.11
Water pressure drop							240	270	320	350	360	380					170	250	310	380
Water pressure drop							12	14	20	23	25	27					7	13	19	26
Water content							0.3										0.3			
Electric heater	230V ±10% - 1ph						230V ±10% - 1ph						230V ±10% - 1ph				230V ±10% - 1ph			
Maximum capacity	1600						1600						1600				1600			
Current drawn	7.3						7.3						7.3				7.3			
Sound levels																				
Sound power level (global)	43	46	54	57	59	61	43	46	54	57	59	61	37	46	53	61	37	46	53	61
Electrical data, motor																				
Power input	38	45	62	74	86	99	38	45	62	74	86	99	4	10	20	49	4	10	20	49
Current drawn	0.16	0.20	0.27	0.32	0.37	0.44	0.16	0.20	0.27	0.32	0.37	0.44	0.06	0.10	0.17	0.39	0.06	0.10	0.17	0.39
FCEER [energy class] - 2 pipes	37	[E]					46	[E]					188	[A]			225	[A]		
FCCOP [energy class]	57	[E]					67	[E]					292	[A]			332	[A]		
FCEER [energy class] - 4 pipes							36	[E]									228	[A]		
FCCOP [energy class]							70	[D]									360	[A]		

Fan speed: L = Low, M = Medium, H = High



Eurovent certified values

* Eurovent conditions: Entering air temperature = 27°C db/47% rh – entering water temperature = 7°C, water temperature difference = 5 K.

** Eurovent conditions: Entering air temperature = 20°C, entering water temperature = 50°C, same water flow rate as in cooling.

*** Eurovent conditions: Entering air temperature = 20°C, entering water temperature = 70°C, water temperature difference = 10 K.

7.2 - Physical and electrical data at Eurovent conditions - 42NL - Size 4

With G1 filter - without plenum

42NL		425						435					
Fan speed (Eurovent certification speeds)		R6 (L)	R5 (M)	R4 (H)	R3	R2	R1 (Max)	R6 (L)	R5 (M)	R4 (H)	R3	R2	R1 (Max)
Air flow	l/s	129	149	209	234	267	301	129	149	209	234	267	301
	m ³ /h	464	537	751	842	960	1085	464	537	751	842	960	1085
Available static pressure	Pa	0	0	0	0	0	0	0	0	0	0	0	0
Cooling mode, two pipes*													
Total cooling capacity	kW	2.43	2.75	3.54	3.83	4.14	4.43	2.76	3.20	4.36	4.79	5.29	5.76
Sensible cooling capacity	kW	1.99	2.27	2.98	3.25	3.57	3.86	2.18	2.52	3.46	3.83	4.27	4.70
Water flow rate	l/s	0.12	0.13	0.17	0.18	0.20	0.21	0.13	0.15	0.21	0.23	0.25	0.28
	l/h	420	470	610	660	710	760	470	550	750	820	910	990
Water pressure drop	kPa	14	18	27	31	36	40	16	21	36	43	51	59
Water content	l	1.0						1.3					
Heating mode, two pipes**													
Heating capacity	kW	3.44	3.95	5.30	5.81	6.38	6.91	3.96	4.58	6.34	7.06	7.93	8.80
Cooling mode, four pipes*													
Total cooling capacity	kW							2.52	2.84	3.69	4.00	4.37	4.72
Sensible cooling capacity	kW							2.05	2.33	3.08	3.37	3.72	4.07
Water flow rate	l/s				NA			0.12	0.14	0.18	0.19	0.21	0.23
	l/h							430	490	630	690	750	810
Water pressure drop	kPa							19	24	38	43	50	58
Water content	l							0.9					
Heating mode, four pipes***													
Heating capacity	kW				NA			3.62	4.20	5.71	6.27	6.90	7.46
Water flow rate	l/s							0.09	0.10	0.14	0.15	0.17	0.18
	l/h							320	370	500	550	610	660
Water pressure drop	kPa							22	29	50	59	70	80
Water content	l							0.5					
Electric heater		230V ±10% - 1ph						230V ±10% - 1ph					
Maximum capacity	W	2000						2000					
Current drawn	A	9.1						9.1					
Sound levels													
Sound power level (global)	dB(A)	45	48	55	58	60	63	45	48	55	58	60	63
Electrical data, motor													
Power input	W	57	69	98	113	129	157	57	69	98	113	129	157
Current drawn	A	0.25	0.30	0.43	0.49	0.57	0.69	0.25	0.30	0.43	0.49	0.57	0.69
FCEER [energy class] - 2 pipes		41	[E]					47	[E]				
FCCOP [energy class]		59	[E]					68	[E]				
FCEER [energy class] - 4 pipes								35	[E]				
FCCOP [energy class]								62	[E]				

42NL		429						439					
Fan speed (Eurovent certification speeds)		2V (L)	3.5V (M)	4V (H)	6V	8V	10V (Max)	2V (L)	3.5V (M)	4V (H)	6V	8V	10V (Max)
Air flow	l/s	67	110	123	169	206	226	67	111	123	169	206	226
	m ³ /h	240	397	444	610	743	814	240	398	444	610	743	814
Available static pressure	Pa	0	0	0	0	0	0	0	0	0	0	0	0
Cooling mode, two pipes*													
Total cooling capacity	kW	1.34	2.12	2.34	3.04	3.52	3.74	1.37	2.37	2.65	3.62	4.32	4.66
Sensible cooling capacity	kW	1.09	1.73	1.91	2.52	2.96	3.17	1.10	1.87	2.08	2.86	3.43	3.71
Water flow rate	l/s	0.06	0.10	0.11	0.14	0.17	0.18	0.06	0.11	0.13	0.17	0.21	0.22
	l/h	230	360	400	520	600	640	230	400	450	620	740	800
Water pressure drop	kPa	4	11	13	21	27	30	4	11	14	27	36	41
Water content	l	1.0						1.3					
Heating mode, two pipes**													
Heating capacity	kW	1.76	3.05	3.29	4.43	5.26	5.65	2.00	3.51	3.78	5.20	6.28	6.84
Cooling mode, four pipes*													
Total cooling capacity	kW				NA			1.41	2.20	2.43	3.15	3.66	3.91
Sensible cooling capacity	kW							1.13	1.78	1.97	2.59	3.05	3.28
Water flow rate	l/s							0.07	0.11	0.12	0.15	0.18	0.19
	l/h							240	380	420	540	630	670
Water pressure drop	kPa							6	15	18	29	37	42
Water content	l							0.9					
Heating mode, four pipes***													
Heating capacity	kW				NA			1.73	3.05	3.46	4.75	5.66	6.10
Water flow rate	l/s							0.04	0.08	0.08	0.12	0.14	0.15
	l/h							150	270	300	420	500	540
Water pressure drop	kPa							6	17	21	36	49	56
Water content	l							0.5					
Electric heater		230V ±10% - 1ph						230V ±10% - 1ph					
Maximum capacity	W	1600						1600					
Current drawn	A	7.3						7.3					
Sound levels													
Sound power level (global)	dB(A)	38	49	52	60	65	67	38	49	52	60	65	67
Electrical data, motor													
Power input	W	6	15	18	42	78	99	6	15	18	42	78	99
Current drawn	A	0.07	0.15	0.18	0.38	0.65	0.80	0.07	0.15	0.18	0.38	0.65	0.80
FCEER [energy class] - 2 pipes		175	[B]					186	[A]				
FCCOP [energy class]		244	[B]					279	[A]				
FCEER [energy class] - 4 pipes								183	[B]				
FCCOP [energy class]								243	[B]				

Fan speed: L = Low, M = Medium, H = High



Eurovent certified values

* Eurovent conditions: Entering air temperature = 27°C db/47% rh – entering water temperature = 7°C, water temperature difference = 5 K.

** Eurovent conditions: Entering air temperature = 20°C, entering water temperature = 50°C, same water flow rate as in cooling.

*** Eurovent conditions: Entering air temperature = 20°C, entering water temperature = 70°C, water temperature difference = 10 K.

7.3 - Physical and electrical data at Eurovent conditions - 42NL - Size 5

With G1 filter - without plenum

42NL		525						535						545							
Fan speed (Eurovent certification speeds)		R6 (L)	R5 (M)	R4 (H)	R3	R2	R1 (Max)	R6 (L)	R5	R4 (M)	R3 (H)	R2	R1 (Max)	R6 (L)	R5	R4 (M)	R3 (H)	R2	R1 (Max)		
Air flow	l/s	150	170	233	275	313	359	150	170	233	275	313	359	150	170	233	275	313	359		
	m ³ /h	540	612	840	991	1127	1291	540	612	840	991	1127	1291	540	612	840	991	1127	1291		
Available static pressure	Pa	0	0	0	0	0	0	0	0	0	0	0	0	0	0	0	0	0	0		
Cooling mode, two pipes*																					
Total cooling capacity	kW	2.76	3.05	3.89	4.36	4.75	5.18	3.21	3.62	4.79	5.45	5.96	6.49	NA							
Sensible cooling capacity	kW	2.28	2.53	3.28	3.72	4.10	4.52	2.53	2.86	3.82	4.39	4.86	5.37								
Water flow rate	l/s	0.13	0.14	0.19	0.21	0.23	0.25	0.15	0.17	0.23	0.26	0.28	0.31								
	l/h	470	520	670	750	820	890	550	620	820	940	1020	1120								
Water pressure drop	kPa	16	19	30	37	43	50	20	26	43	53	62	72								
Water content	l	1.4							1.8												
Heating mode, two pipes**																					
Heating capacity	kW	4.01	4.48	5.84	6.60	7.19	7.80	4.60	5.21	7.01	8.02	8.81	9.61								
Cooling mode, four pipes*																					
Total cooling capacity	kW	NA						2.77	3.08	3.97	4.46	4.86	5.29	2.99	3.35	4.43	5.06	5.59	6.16		
Sensible cooling capacity	kW	NA						2.27	2.53	3.30	3.75	4.13	4.55	2.42	2.72	3.62	4.17	4.64	5.18		
Water flow rate	l/s	NA						0.13	0.15	0.19	0.21	0.23	0.25	0.14	0.16	0.21	0.24	0.27	0.29		
	l/h	NA						480	530	680	770	830	910	510	580	760	870	960	1060		
Water pressure drop	kPa	NA						17	21	33	41	47	55	17	22	37	46	55	65		
Water content	l	NA						1.1							1.4						
Heating mode, four pipes***																					
Heating capacity	kW	NA						3.45	3.79	4.77	5.30	5.71	6.14	4.10	4.59	5.94	6.62	7.10	7.54		
Water flow rate	l/s	NA						0.08	0.09	0.12	0.13	0.14	0.15	0.10	0.11	0.14	0.16	0.17	0.18		
	l/h	NA						300	330	420	470	500	540	360	400	520	580	620	660		
Water pressure drop	kPa	NA						6	7	11	13	15	17	8	9	15	18	20	22		
Water content	l	NA						0.5							0.6						
Electric heater		230V ±10% - 1ph						230V ±10% - 1ph						230V ±10% - 1ph							
Maximum capacity	W	2000						2000						2000							
Current drawn	A	9.1						9.1						9.1							
Sound levels																					
Sound power level (global)	dB(A)	42	46	53	57	59	62	42	46	53	57	59	62	42	46	53	57	59	62		
Electrical data, motor																					
Power input	W	58	67	99	118	137	170	58	67	99	118	137	170	58	67	99	118	137	170		
Current drawn	A	0.26	0.30	0.43	0.52	0.60	0.74	0.26	0.30	0.43	0.52	0.60	0.74	0.26	0.30	0.43	0.52	0.60	0.74		
FCEER [energy class] - 2 pipes		46	[E]					52	[E]												
FCCOP [energy class]		68	[E]					75	[D]												
FCEER [energy class] - 4 pipes								36	[E]					39	[E]						
FCCOP [energy class]								54	[E]					66	[E]						

42NL		529						539						549							
Fan speed (Eurovent certification speeds)		2V (L)	4V	5V (M)	6V (H)	8V	10V (Max)	2V (L)	4V	5.5V (M)	6V (H)	8V	10V (Max)	2V (L)	4V	5.5V (M)	6V (H)	8V	10V (Max)		
Air flow	l/s	82	141	172	188	231	255	82	141	180	188	231	255	82	141	180	188	231	255		
	m ³ /h	295	508	618	675	831	918	295	508	646.5	675	831	918	295	508	646.5	675	831	918		
Available static pressure	Pa	0	0	0	0	0	0	0	0	0	0	0	0	0	0	0	0	0	0		
Cooling mode, two pipes*																					
Total cooling capacity	kW	1.66	2.62	3.07	3.29	3.85	4.13	1.71	3.02	3.81	3.97	4.75	5.14	NA							
Sensible cooling capacity	kW	1.34	2.16	2.55	2.75	3.25	3.51	1.37	2.38	3.01	3.14	3.78	4.12								
Water flow rate	l/s	0.08	0.13	0.15	0.16	0.18	0.20	0.08	0.14	0.18	0.19	0.23	0.24								
	l/h	290	450	530	570	660	710	290	520	655	680	820	880								
Water pressure drop	kPa	6	14	20	23	30	34	6	18	28.5	31	42	48								
Water content	l	1.4							1.8												
Heating mode, two pipes**																					
Heating capacity	kW	2.24	3.79	4.52	4.88	5.79	6.25	2.32	4.31	5.50	5.74	6.94	7.55								
Cooling mode, four pipes*																					
Total cooling capacity	kW	NA						1.61	2.63	3.23	3.35	3.94	4.23	1.68	2.82	3.53	3.67	4.39	4.76		
Sensible cooling capacity	kW	NA						1.30	2.15	2.66	2.76	3.27	3.54	1.36	2.28	2.86	2.98	3.59	3.91		
Water flow rate	l/s	NA						0.08	0.13	0.15	0.16	0.19	0.20	0.08	0.13	0.17	0.18	0.21	0.23		
	l/h	NA						280	450	555	580	680	730	290	480	605	630	750	820		
Water pressure drop	kPa	NA						6	15	23	25	33	37	5	15	24	26	36	42		
Water content	l	NA						1.1							1.4						
Heating mode, four pipes***																					
Heating capacity	kW	NA						2.10	3.28	3.96	4.09	4.74	5.05	2.18	3.86	4.82	5.01	5.89	6.31		
Water flow rate	l/s	NA						0.05	0.08	0.10	0.10	0.12	0.12	0.05	0.09	0.12	0.12	0.14	0.15		
	l/h	NA						180	290	350	360	420	440	190	340	425	440	520	550		
Water pressure drop	kPa	NA						3	6	7.5	8	11	12	3	7	10.5	11	15	16		
Water content	l	NA						0.5							0.6						
Electric heater		230V ±10% - 1ph						230V ±10% - 1ph						230V ±10% - 1ph							
Maximum capacity	W	2000						2000						2000							
Current drawn	A	9.1						9.1						9.1							
Sound levels																					
Sound power level (global)	dB(A)	32	43	47	51	55	58	32	43	49	51	55	58	32	43	49	51	55	58		
Electrical data, motor																					
Power input	W	4	11	18	24	43	58	4	11	21	24	43	58	4	11	21	24	43	58		
Current drawn	A	0.04	0.09	0.13	0.17	0.28	0.39	0.04	0.09	0.15	0.17	0.28	0.39	0.04	0.09	0.15	0.17	0.28	0.39		
FCEER [energy class] - 2 pipes		235	[A]					243	[A]												
FCCOP [energy class]		346	[A]					355	[A]												
FCEER [energy class] - 4 pipes								176	[B]					187	[A]						
FCCOP [energy class]								288	[A]					322	[A]						

Fan speed: L = Low, M = Medium, H = High



Eurovent certified values

* Eurovent conditions: Entering air temperature = 27°C db/47% rh – entering water temperature = 7°C, water temperature difference = 5 K.

** Eurovent conditions: Entering air temperature = 20°C, entering water temperature = 50°C, same water flow rate as in cooling.

*** Eurovent conditions: Entering air temperature = 20°C, entering water temperature = 70°C, water temperature difference = 10 K.

7.5 - Physical and electrical data at Eurovent conditions - 42NH - Size 4

With G1 filter - without plenum

42NH		425					435				
Fan speed (Eurovent certification speeds)		R5 (L)	R4 (M)	R3 (H)	R2	R1 (Max)	R5 (L)	R4 (M)	R3 (H)	R2	R1 (Max)
Air flow	l/s	104	149	181	196	205	104	149	181	196	205
	m ³ /h	375	537	650	706	739	375	537	650	706	739
Available static pressure	Pa	24	50	73	86	95	24	50	73	86	95
Cooling mode, two pipes*											
Total cooling capacity	kW	2.02	2.75	3.19	3.39	3.50	2.21	3.20	3.84	4.13	4.30
Sensible cooling capacity	kW	1.65	2.26	2.66	2.84	2.94	1.76	2.52	3.03	3.27	3.41
Water flow rate	l/s	0.10	0.13	0.15	0.16	0.17	0.11	0.15	0.18	0.20	0.21
	l/h	350	470	550	580	600	380	550	660	710	740
Water pressure drop	kPa	10	18	23	25	27	10	21	29	33	35
Water content	l	1.0					1.3				
Heating mode, two pipes**											
Heating capacity	kW	2.79	3.95	4.69	5.04	5.23	3.19	4.58	5.53	5.98	6.25
Cooling mode, four pipes*											
Total cooling capacity	kW						2.10	2.84	3.31	3.52	3.64
Sensible cooling capacity	kW						1.70	2.33	2.74	2.93	3.04
Water flow rate	l/s				NA		0.10	0.14	0.16	0.17	0.18
	l/h						360	490	570	610	630
Water pressure drop	kPa						13	24	31	35	37
Water content	l						0.9				
Heating mode, four pipes***											
Heating capacity	kW						2.89	4.20	5.03	5.42	5.64
Water flow rate	l/s				NA		0.07	0.10	0.12	0.13	0.14
	l/h						250	370	440	480	500
Water pressure drop	kPa						15	29	40	45	49
Water content	l						0.5				
Electric heater		230V ±10% - 1ph					230V ±10% - 1ph				
Maximum capacity	W	2000					2000				
Current drawn	A	9.1					9.1				
Sound levels											
Sound power level (return and radiated)	dB(A)	44	51	55	58	59	44	51	55	58	59
Sound power level (supply)	dB(A)	47	54	58	60	61	47	54	58	60	61
Electrical data, motor											
Power input	W	83	91	97	104	119	83	91	97	104	119
Current drawn	A	0.43	0.51	0.62	0.67	0.72	0.43	0.51	0.62	0.67	0.72
FCEER [energy class] - 2 pipes		27	[D]				30	[D]			
FCCOP [energy class]		37	[D]				43	[C]			
FCEER [energy class] - 4 pipes							28	[D]			
FCCOP [energy class]							39	[D]			

42NH		429					439				
Fan speed (Eurovent certification speeds)		2V (L)	4V (M)	6V (H)	7V	10V (Max)	2V (L)	4V (M)	6V (H)	7V	10V (Max)
Air flow	l/s	81	148	197	218	231	81	148	197	218	231
	m ³ /h	293	533	709	786	832	293	533	709	786	832
Available static pressure	Pa	15	50	88	109	122	15	50	88	109	122
Cooling mode, two pipes*											
Total cooling capacity	kW	1.61	2.73	3.40	3.65	3.79	1.69	3.17	4.15	4.53	4.74
Sensible cooling capacity	kW	1.31	2.25	2.85	3.09	3.22	1.36	2.50	3.28	3.60	3.78
Water flow rate	l/s	0.08	0.13	0.16	0.18	0.18	0.08	0.15	0.20	0.22	0.23
	l/h	280	470	580	630	650	290	550	710	780	810
Water pressure drop	kPa	6	17	26	29	31	6	21	33	39	42
Water content	l	1.0					1.3				
Heating mode, two pipes**											
Heating capacity	kW	2.17	3.92	5.05	5.50	5.75	2.47	4.55	6.01	6.62	6.97
Cooling mode, four pipes*											
Total cooling capacity	kW						1.69	2.83	3.53	3.81	3.96
Sensible cooling capacity	kW						1.35	2.31	2.94	3.19	3.33
Water flow rate	l/s				NA		0.08	0.14	0.17	0.18	0.19
	l/h						290	490	610	650	680
Water pressure drop	kPa						9	24	35	40	43
Water content	l						0.9				
Heating mode, four pipes***											
Heating capacity	kW						2.19	4.17	5.44	5.93	6.21
Water flow rate	l/s				NA		0.05	0.10	0.13	0.14	0.15
	l/h						190	370	480	520	550
Water pressure drop	kPa						9	29	46	53	58
Water content	l						0.5				
Electric heater		230V ±10% - 1ph					230V ±10% - 1ph				
Maximum capacity	W	1600					1600				
Current drawn	A	7.3					7.3				
Sound levels											
Sound power level (return and radiated)	dB(A)	43	55	61	63	65	43	55	61	63	65
Sound power level (supply)	dB(A)	44	57	65	67	70	44	57	65	67	70
Electrical data, motor											
Power input	W	10.5	43	99	140	172	10.5	43	99	140	172
Current drawn	A	0.12	0.43	0.98	1.26	1.31	0.12	0.43	0.98	1.26	1.31
FCEER [energy class] - 2 pipes		82	[B]				91	[A]			
FCCOP [energy class]		119	[A]				137	[A]			
FCEER [energy class] - 4 pipes							86	[A]			
FCCOP [energy class]							124	[A]			

Fan speed: L = Low, M = Medium, H = High



Eurovent certified values

* Eurovent conditions: Entering air temperature = 27°C db/47% rh – entering water temperature = 7°C, water temperature difference = 5 K.

** Eurovent conditions: Entering air temperature = 20°C, entering water temperature = 50°C, same water flow rate as in cooling.

*** Eurovent conditions: Entering air temperature = 20°C, entering water temperature = 70°C, water temperature difference = 10 K.

7.6 - Physical and electrical data at Eurovent conditions - 42NH - Size 5

With G1 filter - without plenum

42NH	525					535					545										
	R5 (L)	R4 (M)	R3 (H)	R2	R1 (Max)	R5 (L)	R4 (M)	R3 (H)	R2	R1 (Max)	R5 (L)	R4 (M)	R3 (H)	R2	R1 (Max)						
Fan speed (Eurovent certification speeds)																					
Air flow	l/s	213	240	257	268	279	213	240	257	268	279	213	240	257	268	279					
	m ³ /h	767	863	924	964	1004	767	863	924	964	1004	767	863	925	964	1004					
Available static pressure	Pa	40	50	57	62	68	40	50	57	62	68	40	50	57	62	68					
Cooling mode, two pipes*																					
Total cooling capacity	kW	3.63	3.96	4.16	4.28	4.40	4.44	4.90	5.17	5.34	5.50	NA									
Sensible cooling capacity	kW	3.05	3.35	3.53	3.64	3.76	3.52	3.91	4.15	4.29	4.44										
Water flow rate	l/s	0.17	0.19	0.20	0.21	0.21	0.21	0.23	0.25	0.26	0.26										
	l/h	620	680	710	740	760	760	840	890	920	950										
	kPa	28	31	34	36	38	37	45	49	52	54										
Water pressure drop	kPa	28	31	34	36	38	37	45	49	52	54										
Water content	l	1.4											1.8								
Heating mode, two pipes**																					
Heating capacity	kW	5.43	5.96	6.28	6.47	6.66	6.46	7.17	7.60	7.86	8.11										
Cooling mode, four pipes*																					
Total cooling capacity	kW	NA					3.71	4.05	4.25	4.38	4.50	4.10	4.52	4.79	4.95	5.12					
Sensible cooling capacity	kW						3.07	3.37	3.56	3.68	3.79	3.34	3.71	3.93	4.08	4.22					
Water flow rate	l/s						0.18	0.19	0.20	0.21	0.21	0.19	0.22	0.23	0.24	0.24					
	l/h						640	700	730	750	770	700	780	820	850	880					
	kPa						30	35	38	40	42	32	38	42	45	47					
Water pressure drop	kPa	30	35	38	40	42	32	38	42	45	47										
Water content	l	1.1											1.4								
Heating mode, four pipes***																					
Heating capacity	kW	NA					4.48	4.86	5.08	5.22	5.34	5.55	6.05	6.34	6.52	6.67					
Water flow rate	l/s						0.11	0.12	0.13	0.13	0.13	0.14	0.15	0.16	0.16	0.16					
	l/h						390	430	450	460	470	490	530	560	570	590					
	kPa						10	11	12	13	13	13	15	16	17	18					
	l						0.5											0.6			
Electric heater																					
Maximum capacity	W	230V ±10% - 1ph					230V ±10% - 1ph					230V ±10% - 1ph									
Current drawn	A	2000					2000					2000									
Sound levels																					
Sound power level (return and radiated)	dB(A)	53	55	57	58	58	53	55	57	58	58	53	55	57	58	58					
Sound power level (supply)	dB(A)	55	57	59	60	61	55	57	59	60	61	55	57	59	60	61					
Electrical data, motor																					
Power input	W	105	113	117	124	134	105	113	117	124	134	105	113	117	124	134					
Current drawn	A	0.59	0.64	0.67	0.71	0.76	0.59	0.64	0.67	0.71	0.76	0.59	0.64	0.67	0.71	0.76					
FCEER [energy class] - 2 pipes		35	[D]																		
FCCOP [energy class]		52	[C]																		
FCEER [energy class] - 4 pipes							36	[D]													
FCCOP [energy class]							43	[C]													

42NH	529					539					549										
	2V (L)	5V (M)	6V (H)	8V	10V (Max)	2V (L)	5V (M)	6V (H)	8V	10V (Max)	2V (L)	5V (M)	6V (H)	8V	10V (Max)						
Fan speed (Eurovent certification speeds)																					
Air flow	l/s	96	213	244	307	347	96	213	244	307	347	96	213	244	307	347					
	m ³ /h	346	765	878	1105	1249	346	765	878	1105	1249	346	765	878	1105	1249					
Available static pressure	Pa	10	50	66	104	133	10	50	66	104	133	10	50	66	104	133					
Cooling mode, two pipes*																					
Total cooling capacity	kW	1.90	3.63	4.01	4.69	5.08	2.03	4.43	4.97	5.88	6.35	NA									
Sensible cooling capacity	kW	1.55	3.04	3.39	4.04	4.42	1.62	3.52	3.97	4.79	5.24										
Water flow rate	l/s	0.09	0.17	0.19	0.23	0.24	0.10	0.21	0.24	0.28	0.30										
	l/h	330	620	690	810	870	350	760	850	1010	1090										
	kPa	8	27	32	42	48	8	37	46	61	69										
Water pressure drop	kPa	8	27	32	42	48	8	37	46	61	69										
Water content	l	1.4											1.8								
Heating mode, two pipes**																					
Heating capacity	kW	2.62	5.42	6.05	7.10	7.65	2.81	6.45	7.28	8.70	9.42										
Cooling mode, four pipes*																					
Total cooling capacity	kW	NA					1.86	3.70	4.10	4.80	5.19	1.96	4.09	4.59	5.51	6.02					
Sensible cooling capacity	kW						1.51	3.06	3.42	4.07	4.45	1.58	3.33	3.76	4.57	5.04					
Water flow rate	l/s						0.09	0.18	0.19	0.23	0.25	0.09	0.19	0.22	0.26	0.29					
	l/h						320	640	700	820	890	340	700	790	950	1030					
	kPa						8	30	35	46	53	7	32	39	53	62					
Water pressure drop	kPa	8	30	35	46	53	7	32	39	53	62										
Water content	l	1.1											1.4								
Heating mode, four pipes***																					
Heating capacity	kW	NA					2.40	4.47	4.91	5.65	6.04	2.61	5.54	6.13	7.03	7.44					
Water flow rate	l/s						0.06	0.11	0.12	0.14	0.15	0.06	0.14	0.15	0.17	0.18					
	l/h						210	390	430	500	530	230	490	540	620	650					
	kPa						3	10	11	15	16	4	13	16	20	22					
	l						0.5											0.6			
Electric heater																					
Maximum capacity	W	230V ±10% - 1ph					230V ±10% - 1ph					230V ±10% - 1ph									
Current drawn	A	2000					2000					2000									
Sound levels																					
Sound power level (return and radiated)	dB(A)	35	53	58	63	67	35	53	58	63	67	35	53	58	63	67					
Sound power level (supply)	dB(A)	36	57	61	66	70	36	57	61	66	70	36	57	61	66	70					
Electrical data, motor																					
Power input	W	9	52	78	146	212	9	52	78	146	212	9	52	78	146	212					
Current drawn	A	0.12	0.67	0.95	1.58	1.88	0.12	0.67	0.95	1.58	1.88	0.12	0.67	0.95	1.58	1.88					
FCEER [energy class] - 2 pipes		100	[A]																		
FCCOP [energy class]		150	[A]																		
FCEER [energy class] - 4 pipes							100	[A]													
FCCOP [energy class]							131	[A]													

Fan speed: L = Low, M = Medium, H = High



Eurovent certified values

* Eurovent conditions: Entering air temperature = 27°C db/47% rh – entering water temperature = 7°C, water temperature difference = 5 K.

** Eurovent conditions: Entering air temperature = 20°C, entering water temperature = 50°C, same water flow rate as in cooling.

*** Eurovent conditions: Entering air temperature = 20°C, entering water temperature = 70°C, water temperature difference = 10 K.

7.7 - Physical and electrical data at Eurovent conditions - 42NH - Sizes 6 and 7

With G1 filter - without plenum

42NH		635					645					639				649			
Fan speed (Eurovent certification speeds)		R5	R4	R3	R2	R1	R5	R4	R3	R2	R1	2V	6V	7V	10V	2V	7V	8V	10V
		(L)	(M)	(H)	(Max)	(L)	(M)	(H)	(Max)	(L)	(M)	(H)	(Max)	(L)	(M)	(H)	(Max)		
Air flow	l/s	200	298	397	460	499	200	298	397	460	499	102	269	303	389	111	327	364	425
	m ³ /h	720	1072	1428	1657	1796	720	1072	1428	1657	1796	368	967	1089	1400	399	1176	1310	1531
Available static pressure	Pa	13	28	50	67	79	13	28	50	67	79	7	50	63	105	6	50	62	85
Cooling mode, two pipes*																			
Total cooling capacity	kW	4.22	6.04	7.55	8.33	8.77	4.77	7.03	8.86	9.79	10.28	2.18	5.52	6.11	7.45	2.45	7.62	8.31	9.29
Sensible cooling capacity	kW	3.36	4.85	6.18	6.92	7.36	3.63	5.37	6.90	7.75	8.23	1.74	4.42	4.91	6.08	1.93	5.84	6.42	7.29
Water flow rate	l/s	0.20	0.29	0.36	0.40	0.42	0.23	0.34	0.42	0.47	0.49	0.11	0.26	0.29	0.36	0.12	0.36	0.40	0.44
	l/h	730	1040	1300	1430	1510	820	1210	1520	1680	1770	380	950	1050	1280	420	1310	1430	1600
Water pressure drop	kPa	11	23	34	40	44	11	24	38	44	48	3	19	24	33	4	28	34	40
Water content	l	1.5					2					1.5				2			
Heating mode, two pipes**																			
Heating capacity	kW	6.09	8.83	11.29	12.66	13.40	6.57	9.69	12.45	13.95	14.75	3.14	8.04	8.95	11.11	3.47	10.55	11.59	13.15
Cooling mode, four pipes*																			
Total cooling capacity	kW						3.99	5.61	6.87	7.47	7.82					2.09	5.68	6.16	6.78
Sensible cooling capacity	kW						3.24	4.63	5.80	6.43	6.80					1.70	4.69	5.12	5.72
Water flow rate	l/s						0.19	0.27	0.33	0.36	0.37					0.10	0.27	0.29	0.33
	l/h						690	960	1180	1280	1340					360	980	1060	1170
Water pressure drop	kPa						10	20	29	34	36					3	20	24	29
Water content	l						1.3									1.3			
Heating mode, four pipes***																			
Heating capacity	kW						5.67	7.82	9.27	9.88	10.17					2.93	7.90	8.48	9.18
Water flow rate	l/s						0.14	0.19	0.23	0.24	0.25					0.07	0.19	0.21	0.23
	l/h						500	690	810	870	890					260	690	750	810
Water pressure drop	kPa						7	12	17	19	20					2	13	14	16
Water content	l						0.7									0.7			
Electric heater																			
Maximum capacity	W	230V ±10% - 1ph					230V ±10% - 1ph					230V ±10% - 1ph				230V ±10% - 1ph			
Current drawn	A	3200					3200					3200				3200			
		14.6					14.6					14.6				14.6			
Sound levels																			
Sound power level (return and radiated)	dB(A)	50	56	58	61	62	50	56	58	61	62	39	62	64	70	39	64	67	70
Sound power level (supply)	dB(A)	50	59	62	65	66	50	59	62	65	66	45	58	61	68	45	61	64	68
Electrical data, motor																			
Power input	W	185	217	225	242	286	185	217	225	242	286	9	76	106	222	9	111	153	233
Current drawn	A	0.96	1.11	1.28	1.38	1.55	0.96	1.11	1.28	1.38	1.55	0.09	0.71	1.02	2.01	0.09	0.71	1.02	2.01
FCEER [energy class] - 2 pipes		30	[D]				35	[D]				100	[A]			92	[A]		
FCCOP [energy class]		44	[C]				48	[C]				152	[A]			135	[A]		
FCEER [energy class] - 4 pipes							28	[D]								72	[B]		
FCCOP [energy class]							38	[D]								107	[A]		

42NH		735					745					739				749			
Fan speed (Eurovent certification speeds)		R5	R4	R3	R2	R1	R5	R4	R3	R2	R1	2V	7V	8V	10V	2V	7V	8V	10V
		(L)	(M)	(H)	(Max)	(L)	(M)	(H)	(Max)	(L)	(M)	(H)	(Max)	(L)	(M)	(H)	(Max)		
Air flow	l/s	148	218	374	533	600	148	218	374	533	600	147	441	477	529	147	441	477	529
	m ³ /h	534	785	1346	1918	2161	534	785	1346	1918	2161	530	1586	1717	1906	530	1586	1717	1906
Available static pressure	Pa	4	8	25	50	63	4	8	25	50	63	6	50	59	72	6	50	59	72
Cooling mode, two pipes*																			
Total cooling capacity	kW	3.37	4.90	7.92	10.30	11.14	3.61	5.33	8.84	11.68	12.65	3.34	9.00	9.54	10.26	3.58	10.10	10.76	11.61
Sensible cooling capacity	kW	2.60	3.79	6.22	8.31	9.09	2.73	4.01	6.71	9.09	9.97	2.59	7.14	7.62	8.27	2.71	7.75	8.31	9.04
Water flow rate	l/s	0.16	0.23	0.38	0.49	0.53	0.17	0.26	0.42	0.56	0.60	0.16	0.43	0.46	0.49	0.17	0.48	0.51	0.55
	l/h	580	840	1360	1770	1910	620	920	1520	2010	2170	570	1550	1640	1760	620	1740	1850	1990
Water pressure drop	kPa	8	17	42	66	75	7	15	41	66	75	8	52	57	65	7	51	57	65
Water content	l	2					2.6					2				2.6			
Heating mode, two pipes**																			
Heating capacity	kW	4.52	6.48	10.68	14.63	16.15	4.59	6.72	11.38	15.82	17.52	4.48	12.38	13.29	14.54	4.56	13.29	14.32	15.72
Cooling mode, four pipes*																			
Total cooling capacity	kW	2.98	4.19	6.58	8.61	9.36	3.52	5.18	8.41	10.80	11.56	2.96	7.48	7.94	8.57	3.49	9.52	10.06	10.76
Sensible cooling capacity	kW	2.40	3.41	5.45	7.29	7.99	2.68	3.93	6.47	8.59	9.33	2.39	6.25	6.67	7.25	2.65	7.42	7.90	8.55
Water flow rate	l/s	0.14	0.20	0.31	0.41	0.45	0.17	0.25	0.40	0.52	0.55	0.14	0.36	0.38	0.41	0.17	0.46	0.48	0.51
	l/h	510	720	1130	1480	1610	600	890	1440	1860	1990	510	1280	1360	1470	600	1640	1730	1850
Water pressure drop	kPa	8	16	35	56	65	9	19	47	72	81	8	44	49	56	9	58	64	72
Water content	l	1.3					1.7					1.3				1.7			
Heating mode, four pipes***																			
Heating capacity	kW	4.17	5.96	9.64	12.76	13.87	4.76	7.22	12.05	15.70	16.91	4.14	11.03	11.75	12.70	4.72	13.73	14.56	15.63
Water flow rate	l/s	0.10	0.14	0.24	0.31	0.34	0.12	0.18	0.29	0.38	0.41	0.10	0.27	0.29	0.31	0.11	0.34	0.36	0.38
	l/h	370	520	850	1120	1220	420	630	1060	1380	1490	360	970	1030	1120	410	1210	1280	1370
Water pressure drop	kPa	5	9	22	36	41	6	11	28	45	51	5	28	31	36	5	35	39	44
Water content	l	0.7					0.9					0.7				0.9			
Electric heater																			
Maximum capacity	W	230V ±10% - 1ph					230V ±10% - 1ph					230V ±10% - 1ph				230V ±10% - 1ph			
Current drawn	A	3200					3200					3000				3000			
		14.6					14.6					13.7				13.7			
Sound levels																			
Sound power level (return and radiated)	dB(A)	41	48	57	63	64	41	48	57	63	64	46	60	62	64	46	60	62	64
Sound power level (supply)	dB(A)	42	48	58	66	68	42	48	58	66	68	45	61	63	66	45	61	63	66
Electrical data, motor																			
Power input	W	174	227	282	316	321	174	227	282	316	321	10	137	177	240	10	137	177	240
Current drawn	A	0.84	1.08	1.40	1.74	1.86	0.84	1.08	1.40	1.74	1.86	0.11	1.11	1.38	1.85	0.11	1.11	1.38	1.85
FCEER [energy class] - 2																			

7.8 - Thermal capacities

7.8.1 - Cooling capacity 2-pipe water coil

Entering / leaving water temperature, °C		42NH & NL 225 / 229																	
		Relative humidity 50%																	
		Air flow, m ³ /h (l/s)																	
		200 (56)			250 (69)			350 (97)			400 (111)			450 (125)			500 (139)		
		Entering air dry-bulb temperature, °C																	
		27	25	23	27	25	23	27	25	23	27	25	23	27	25	23			
6-12	TC	1.22	0.96	0.74	1.48	1.16	0.90	1.92	1.52	1.18	2.10	1.68	1.31	2.26	1.81	1.42	2.40	1.92	1.52
	SHC	0.90	0.79	0.69	1.10	0.97	0.85	1.45	1.29	1.13	1.60	1.43	1.25	1.74	1.56	1.37	1.87	1.67	1.47
	SAT	12.7	12.2	11.6	12.8	12.3	11.6	13.2	12.5	11.7	13.4	12.6	11.7	13.6	12.8	11.8	13.8	12.9	11.8
	WF	178	140	107	216	170	131	280	222	172	306	244	190	330	263	206	349	280	221
10-15	TC	0.84	0.65	0.52	1.02	0.79	0.64	1.34	1.05	0.85	1.47	1.17	0.94	1.58	1.27	1.03	1.68	1.37	1.10
	SHC	0.74	0.64	0.52	0.91	0.79	0.64	1.21	1.05	0.85	1.34	1.16	0.94	1.46	1.27	1.03	1.57	1.36	1.10
	SAT	14.8	13.8	12.0	14.9	13.8	12.0	15.0	13.8	12.0	15.1	13.8	12.0	15.2	13.8	12.0	15.3	13.9	12.0
	WF	145	112	90	176	137	110	230	181	146	253	201	162	273	219	177	289	235	190

Entering / leaving water temperature, °C		42NH & NL 235 / 239 / 279																	
		Relative humidity 50%																	
		Air flow, m ³ /h (l/s)																	
		200 (56)			250 (69)			350 (97)			400 (111)			450 (125)			500 (139)		
		Entering air dry-bulb temperature, °C																	
		27	25	23	27	25	23	27	25	23	27	25	23	27	25	23			
6-12	TC	1.41	1.16	0.89	1.79	1.42	1.09	2.37	1.88	1.45	2.62	2.08	1.61	2.85	2.27	1.76	3.05	2.44	1.90
	SHC	0.99	0.90	0.78	1.25	1.11	0.97	1.69	1.49	1.31	1.88	1.67	1.46	2.06	1.84	1.61	2.24	1.99	1.75
	SAT	11.7	11.2	10.9	11.5	11.3	11.0	11.9	11.6	11.1	12.2	11.8	11.2	12.4	11.9	11.3	12.6	12.1	11.4
	WF	205	181	138	280	221	170	371	293	227	410	325	252	445	354	275	477	381	297
10-15	TC	0.96	0.73	0.58	1.17	0.90	0.72	1.56	1.21	0.97	1.73	1.35	1.08	1.89	1.48	1.19	2.03	1.61	1.29
	SHC	0.81	0.71	0.58	1.00	0.87	0.72	1.35	1.18	0.97	1.51	1.32	1.08	1.67	1.46	1.19	1.82	1.58	1.29
	SAT	14.4	13.6	12.0	14.5	13.7	12.0	14.6	13.7	12.0	14.7	13.7	12.0	14.8	13.7	12.0	14.9	13.8	12.0
	WF	165	126	101	202	155	124	268	209	167	298	233	187	325	255	205	350	277	222

Entering / leaving water temperature, °C		42NH & NL 325 / 329																	
		Relative humidity 50%																	
		Air flow, m ³ /h (l/s)																	
		300 (83)			350 (97)			450 (125)			550 (153)			600 (167)			700 (194)		
		Entering air dry-bulb temperature, °C																	
		27	25	23	27	25	23	27	25	23	27	25	23	27	25	23			
6-12	TC	1.57	1.20	0.95	1.76	1.35	1.08	2.12	1.63	1.32	2.44	1.89	1.54	2.59	2.01	1.64	2.85	2.24	1.84
	SHC	1.23	1.08	0.93	1.39	1.22	1.06	1.70	1.50	1.30	1.98	1.75	1.51	2.11	1.87	1.62	2.36	2.10	1.82
	SAT	13.6	13.1	11.9	13.7	13.1	11.9	14.0	13.3	11.9	14.2	13.4	11.9	14.3	13.4	12.0	14.4	13.5	12.0
	WF	229	175	139	257	197	157	309	238	192	356	275	224	377	293	239	416	326	268
10-15	TC	1.07	0.87	0.69	1.20	0.98	0.78	1.47	1.20	0.95	1.71	1.40	1.11	1.82	1.50	1.19	2.04	1.68	1.33
	SHC	1.02	0.86	0.69	1.16	0.98	0.78	1.42	1.20	0.95	1.66	1.40	1.11	1.77	1.50	1.19	1.99	1.68	1.33
	SAT	15.4	13.8	12.0	15.5	13.8	12.0	15.5	13.9	12.0	15.5	13.9	12.0	15.6	13.9	12.0	15.6	13.9	12.0
	WF	184	150	118	208	169	134	252	207	164	294	242	192	314	258	205	351	290	230

Entering / leaving water temperature, °C		42NH & NL 335 / 339																	
		Relative humidity 50%																	
		Air flow, m ³ /h (l/s)																	
		300 (83)			350 (97)			450 (125)			550 (153)			600 (167)			700 (194)		
		Entering air dry-bulb temperature, °C																	
		27	25	23	27	25	23	27	25	23	27	25	23	27	25	23			
6-12	TC	2.00	1.56	1.20	2.27	1.76	1.36	2.75	2.15	1.66	3.19	2.50	1.94	3.40	2.66	2.07	3.77	2.97	2.32
	SHC	1.44	1.27	1.11	1.65	1.45	1.27	2.04	1.80	1.56	2.40	2.12	1.85	2.57	2.27	1.98	2.89	2.57	2.24
	SAT	12.1	11.9	11.3	12.4	12.1	11.4	12.7	12.3	11.6	13.0	12.5	11.7	13.1	12.6	11.7	13.4	12.7	11.8
	WF	292	227	175	330	257	198	401	313	242	465	364	283	495	387	302	550	432	338
10-15	TC	1.37	1.04	0.83	1.56	1.18	0.95	1.89	1.46	1.17	2.20	1.72	1.38	2.35	1.84	1.47	2.63	2.08	1.66
	SHC	1.19	1.03	0.83	1.36	1.17	0.95	1.68	1.45	1.17	1.99	1.71	1.38	2.13	1.83	1.47	2.41	2.07	1.66
	SAT	14.6	13.8	12.0	14.7	13.8	12.0	14.9	13.8	12.0	15.0	13.8	12.0	15.0	13.8	12.0	15.1	13.8	12.0
	WF	237	179	143	268	204	164	326	252	202	380	296	237	405	317	254	452	358	287

Legend:

- TC Total cooling capacity (kW)
- SHC Sensible cooling capacity (kW)
- SAT Supply air temperature (°C)
- WF Water flow rate (l/h)

NOTE:

- To convert l/h to l/s, divide by 3600.
- Operating limits - air discharge temperature 12°C when the unit is installed in an ambient temperature of 27°C dry bulb and 65% relative humidity.

7.8.1 - Cooling capacity 2-pipe water coil (continued)

Entering / leaving water temperature, °C		42NH & NL 425 / 429																	
		Relative humidity 50%																	
		Air flow, m³/h (l/s)																	
		450 (125)			550 (153)			750 (208)			850 (236)			950 (264)			1050 (292)		
		Entering air dry-bulb temperature, °C																	
		27	25	23	27	25	23	27	25	23	27	25	23	27	25	23	27	25	23
6-12	TC	2.53	1.97	1.53	3.00	2.34	1.82	3.80	3.01	2.36	4.14	3.28	2.59	4.42	3.53	2.80	4.67	3.73	2.99
	SHC	1.92	1.69	1.47	2.29	2.02	1.76	2.95	2.62	2.28	3.24	2.88	2.52	3.50	3.12	2.73	3.74	3.33	2.93
	SAT	13.2	12.6	11.8	13.3	12.7	11.8	13.6	12.8	11.8	13.8	12.9	11.8	13.9	13.0	11.9	14.1	13.1	11.9
	WF	369	287	222	438	342	266	554	438	343	603	478	378	645	514	408	680	544	436
10-15	TC	1.74	1.37	1.10	2.07	1.64	1.31	2.64	2.13	1.71	2.89	2.34	1.88	3.11	2.53	2.03	3.30	2.70	2.17
	SHC	1.58	1.36	1.10	1.89	1.63	1.31	2.45	2.12	1.71	2.70	2.34	1.88	2.93	2.53	2.03	3.14	2.70	2.17
	SAT	15.1	13.8	12.0	15.1	13.8	12.0	15.2	13.8	12.0	15.3	13.8	12.0	15.4	13.8	12.0	15.4	13.9	12.0
	WF	300	236	189	357	282	227	455	366	294	498	404	324	535	436	350	569	466	375

Entering / leaving water temperature, °C		42NH & NL 435 / 439																	
		Relative humidity 50%																	
		Air flow, m³/h (l/s)																	
		450 (125)			550 (153)			750 (208)			850 (236)			950 (264)			1050 (292)		
		Entering air dry-bulb temperature, °C																	
		27	25	23	27	25	23	27	25	23	27	25	23	27	25	23	27	25	23
6-12	TC	2.89	2.24	1.74	3.55	2.77	2.16	4.74	3.73	2.92	5.26	4.16	3.26	5.72	4.55	3.58	6.13	4.88	3.86
	SHC	2.10	1.85	1.61	2.57	2.27	1.98	3.46	3.06	2.68	3.85	3.42	3.00	4.22	3.76	3.30	4.57	4.07	3.59
	SAT	12.4	12.1	11.4	12.3	12.0	11.3	12.4	12.0	11.3	12.6	12.1	11.4	12.7	12.2	11.4	12.9	12.3	11.5
	WF	421	327	254	517	404	314	691	544	426	766	607	476	833	663	521	893	712	562
10-15	TC	1.98	1.53	1.22	2.43	1.88	1.50	3.26	2.54	2.04	3.63	2.84	2.28	3.96	3.12	2.51	4.26	3.37	2.73
	SHC	1.73	1.50	1.22	2.11	1.84	1.50	2.84	2.48	2.04	3.18	2.77	2.28	3.49	3.06	2.51	3.79	3.31	2.73
	SAT	14.7	13.7	12.0	14.7	13.7	12.0	14.7	13.7	12.0	14.7	13.7	12.0	14.8	13.7	12.0	14.9	13.7	12.0
	WF	341	263	210	418	324	259	562	437	351	626	489	394	682	537	433	733	581	470

Entering / leaving water temperature, °C		42NH & NL 525 / 529																	
		Relative humidity 50%																	
		Air flow, m³/h (l/s)																	
		550 (153)			650 (181)			850 (236)			1000 (278)			1150 (319)			1300 (361)		
		Entering air dry-bulb temperature, °C																	
		27	25	23	27	25	23	27	25	23	27	25	23	27	25	23	27	25	23
6-12	TC	2.98	2.34	1.81	3.40	2.68	2.08	4.18	3.31	2.59	4.69	3.73	2.94	5.14	4.12	3.26	5.55	4.47	3.56
	SHC	2.28	2.01	1.75	2.62	2.32	2.02	3.26	2.89	2.52	3.70	3.29	2.87	4.10	3.66	3.19	4.47	4.00	3.50
	SAT	13.4	12.7	11.8	13.5	12.8	11.8	13.7	12.9	11.9	13.9	13.0	11.9	14.1	13.1	11.9	14.2	13.2	11.9
	WF	434	341	263	496	391	304	609	482	377	683	544	428	750	600	475	808	651	518
10-15	TC	2.07	1.63	1.31	2.37	1.88	1.51	2.92	2.35	1.88	3.29	2.67	2.14	3.64	2.97	2.38	3.96	3.25	2.61
	SHC	1.89	1.63	1.31	2.18	1.88	1.51	2.72	2.35	1.88	3.09	2.67	2.14	3.45	2.97	2.38	3.77	3.25	2.61
	SAT	15.1	13.9	12.0	15.2	13.9	12.0	15.3	13.9	12.0	15.3	13.9	12.0	15.4	13.9	12.0	15.4	13.9	12.0
	WF	357	282	225	408	324	260	503	405	324	568	460	369	627	512	410	682	561	449

Entering / leaving water temperature, °C		42NH & NL 535 / 539																	
		Relative humidity 50%																	
		Air flow, m³/h (l/s)																	
		550 (153)			650 (181)			850 (236)			1000 (278)			1150 (319)			1300 (361)		
		Entering air dry-bulb temperature, °C																	
		27	25	23	27	25	23	27	25	23	27	25	23	27	25	23	27	25	23
6-12	TC	3.52	2.75	2.13	4.13	3.25	2.52	5.24	4.15	3.23	5.93	4.73	3.69	6.52	5.21	4.10	7.01	5.61	4.45
	SHC	2.56	2.26	1.96	3.01	2.66	2.31	3.85	3.41	2.97	4.40	3.92	3.42	4.90	4.37	3.83	5.35	4.77	4.19
	SAT	12.4	12.0	11.4	12.4	12.0	11.4	12.6	12.1	11.4	12.8	12.2	11.4	13.1	12.4	11.5	13.3	12.6	11.6
	WF	512	401	311	603	474	367	763	604	471	864	689	538	950	759	598	1022	817	649
10-15	TC	2.42	1.88	1.49	2.85	2.21	1.76	3.63	2.83	2.26	4.13	3.25	2.60	4.55	3.62	2.90	4.92	3.94	3.17
	SHC	2.11	1.82	1.49	2.48	2.15	1.76	3.17	2.75	2.26	3.64	3.17	2.60	4.07	3.55	2.90	4.45	3.87	3.17
	SAT	14.7	13.7	12.0	14.7	13.7	12.0	14.7	13.7	12.0	14.8	13.7	12.0	14.9	13.7	12.0	15.1	13.8	12.0
	WF	416	323	256	490	381	303	625	488	390	711	559	448	784	624	500	848	678	545

Legend:

TC Total cooling capacity (kW)
SHC Sensible cooling capacity (kW)
SAT Supply air temperature (°C)
WF Water flow rate (l/h)

NOTE:

- To convert l/h to l/s, divide by 3600.
- Operating limits - air discharge temperature 12°C when the unit is installed in an ambient temperature of 27°C dry bulb and 65% relative humidity.

7.8.1 - Cooling capacity 2-pipe water coil (continued)

Entering / leaving water temperature, °C		42NH 635 / 639																	
		Relative humidity 50%																	
		Air flow, m³/h (l/s)																	
		300 (83)			350 (97)			450 (125)			550 (153)			600 (167)			700 (194)		
		Entering air dry-bulb temperature, °C																	
		27	25	23	27	25	23	27	25	23	27	25	23	27	25	23			
6-12	TC	4.40	3.42	2.64	6.63	5.18	4.04	8.21	6.46	5.07	8.94	7.07	5.58	9.45	7.51	5.93	10.07	8.02	6.38
	SHC	3.24	2.84	2.48	4.92	4.34	3.80	6.20	5.49	4.81	6.84	6.08	5.33	7.29	6.50	5.69	7.87	7.03	6.16
	SAT	12.6	12.2	11.5	12.8	12.3	11.6	13.1	12.5	11.6	13.3	12.7	11.7	13.5	12.8	11.7	13.7	12.9	11.8
	WF	640	497	384	965	755	588	1196	940	738	1302	1030	813	1376	1093	864	1467	1169	929
10-15	TC	2.89	2.36	1.87	4.58	3.60	2.88	5.71	4.54	3.63	6.26	5.01	4.01	6.63	5.34	4.28	7.09	5.75	4.61
	SHC	2.72	2.32	1.87	4.07	3.53	2.88	5.16	4.48	3.63	5.71	4.96	4.01	6.10	5.29	4.28	6.60	5.71	4.61
	SAT	14.3	13.7	12.0	14.9	13.7	12.0	15.0	13.8	12.0	15.1	13.8	12.0	15.2	13.8	12.0	15.3	13.8	12.0
	WF	497	406	323	788	620	495	984	781	626	1077	863	691	1141	919	737	1220	990	794

Entering / leaving water temperature, °C		42NH 645 / 649																	
		Relative humidity 50%																	
		Air flow, m³/h (l/s)																	
		700 (194)			1100 (306)			1450 (403)			1650 (458)			1800 (500)			2000 (556)		
		Entering air dry-bulb temperature, °C																	
		27	25	23	27	25	23	27	25	23	27	25	23	27	25	23			
6-12	TC	4.97	3.90	2.97	7.76	6.11	4.72	9.67	7.62	5.90	10.52	8.29	6.44	11.10	8.77	6.79	11.78	9.37	7.26
	SHC	3.51	3.09	2.69	5.48	4.84	4.23	6.96	6.14	5.39	7.68	6.79	5.96	8.19	7.26	6.36	8.83	7.86	6.87
	SAT	11.7	11.5	11.2	11.7	11.5	11.1	12.1	11.8	11.3	12.4	12.0	11.4	12.6	12.2	11.5	12.9	12.3	11.6
	WF	724	568	433	1130	890	687	1408	1109	860	1532	1208	938	1615	1277	989	1716	1364	1057
10-15	TC	3.22	2.60	2.07	5.37	4.09	3.26	6.70	5.16	4.13	7.30	5.68	4.55	7.71	6.04	4.84	8.23	6.49	5.20
	SHC	2.93	2.52	2.07	4.50	3.94	3.26	5.73	5.02	4.13	6.35	5.55	4.55	6.79	5.93	4.84	7.35	6.40	5.20
	SAT	14.0	13.6	12.0	14.3	13.6	12.0	14.5	13.7	12.0	14.7	13.7	12.0	14.8	13.7	12.0	14.9	13.8	12.0
	WF	554	449	356	924	704	562	1153	889	712	1257	978	784	1327	1041	833	1416	1118	895

Entering / leaving water temperature, °C		42NH 735 / 739																	
		Relative humidity 50%																	
		Air flow, m³/h (l/s)																	
		550 (153)			800 (222)			1350 (375)			1950 (542)			2200 (611)			2400 (667)		
		Entering air dry-bulb temperature, °C																	
		27	25	23	27	25	23	27	25	23	27	25	23	27	25	23			
6-12	TC	3.73	2.91	2.24	5.39	4.23	3.28	8.64	6.85	5.36	11.31	9.06	7.18	12.23	9.83	7.84	12.93	10.40	8.33
	SHC	2.67	2.35	2.04	3.85	3.39	2.96	6.24	5.54	4.85	8.40	7.50	6.61	9.18	8.23	7.28	9.80	8.78	7.77
	SAT	12.0	11.8	11.2	12.0	11.7	11.2	12.3	11.9	11.2	12.9	12.3	11.4	13.1	12.4	11.5	13.3	12.5	11.5
	WF	544	424	327	786	617	478	1259	998	780	1648	1319	1046	1781	1431	1142	1883	1514	1213
10-15	TC	2.42	1.98	1.57	3.71	2.87	2.28	5.97	4.68	3.74	7.88	6.31	5.09	8.58	6.88	5.57	9.09	7.30	5.94
	SHC	2.22	1.90	1.57	3.16	2.75	2.28	5.14	4.49	3.74	6.97	6.12	5.09	7.66	6.70	5.57	8.18	7.15	5.94
	SAT	14.1	13.6	12.0	14.5	13.6	12.0	14.6	13.6	12.0	14.9	13.7	12.0	15.0	13.7	12.0	15.0	13.7	12.0
	WF	417	340	270	639	493	393	1028	805	644	1357	1086	876	1477	1184	959	1564	1257	1022

Entering / leaving water temperature, °C		42NH 745 / 749																	
		Relative humidity 50%																	
		Air flow, m³/h (l/s)																	
		550 (153)			800 (222)			1350 (375)			1950 (542)			2200 (611)			2400 (667)		
		Entering air dry-bulb temperature, °C																	
		27	25	23	27	25	23	27	25	23	27	25	23	27	25	23			
6-12	TC	4.01	3.13	2.40	5.89	4.63	3.57	9.66	7.65	5.96	12.87	10.30	8.07	13.94	11.17	8.79	14.72	11.80	9.32
	SHC	2.81	2.46	2.14	4.10	3.60	3.15	6.77	5.98	5.24	9.24	8.23	7.23	10.13	9.04	7.96	10.81	9.65	8.50
	SAT	11.4	11.4	11.0	11.3	11.2	10.9	11.5	11.3	10.9	12.1	11.7	11.1	12.4	11.9	11.2	12.6	12.0	11.3
	WF	585	456	350	857	674	521	1407	1114	868	1875	1500	1175	2030	1627	1281	2145	1718	1358
10-15	TC	2.60	2.11	1.66	4.06	3.10	2.45	6.68	5.14	4.08	8.96	7.01	5.60	9.72	7.68	6.15	10.28	8.16	6.55
	SHC	2.33	2.00	1.66	3.34	2.92	2.44	5.53	4.84	4.07	7.62	6.68	5.60	8.39	7.37	6.15	8.97	7.87	6.55
	SAT	13.8	13.5	12.0	14.1	13.4	12.0	14.2	13.4	12.0	14.5	13.5	12.0	14.6	13.6	12.0	14.7	13.6	12.0
	WF	447	363	286	698	534	422	1149	886	703	1542	1207	965	1674	1322	1059	1771	1405	1129

Legend:

- TC Total cooling capacity (kW)
- SHC Sensible cooling capacity (kW)
- SAT Supply air temperature (°C)
- WF Water flow rate (l/h)

NOTE:

- To convert l/h to l/s, divide by 3600.
- Operating limits - air discharge temperature 12°C when the unit is installed in an ambient temperature of 27°C dry bulb and 65% relative humidity.

7.8.2 - Cooling capacity 4-pipe water coil

Entering / leaving water temperature, °C		42NH & NL 235 / 239 / 279																	
		Relative humidity 50%																	
		Air flow, m³/h (l/s)																	
		200 (56)			250 (69)			350 (97)			400 (111)			450 (125)			500 (139)		
		Entering air dry-bulb temperature, °C																	
		27	25	23	27	25	23	27	25	23	27	25	23	27	25	23			
6-12	TC	1.04	0.81	0.64	1.26	0.98	0.77	1.65	1.29	1.02	1.81	1.43	1.13	1.96	1.55	1.23	2.09	1.66	1.32
	SHC	0.82	0.72	0.62	1.00	0.88	0.75	1.33	1.17	1.00	1.48	1.30	1.11	1.61	1.42	1.22	1.74	1.53	1.31
	SAT	13.7	13.0	11.8	13.8	13.1	11.9	14.1	13.2	11.9	14.2	13.3	11.9	14.3	13.3	11.9	14.4	13.4	12.0
	WF	152	118	93	184	143	112	240	189	149	264	208	164	285	226	179	304	241	192
10-15	TC	0.74	0.58	0.46	0.90	0.71	0.55	1.18	0.94	0.74	1.30	1.04	0.82	1.41	1.13	0.89	1.51	1.22	0.96
	SHC	0.68	0.58	0.46	0.83	0.71	0.55	1.11	0.94	0.74	1.23	1.04	0.82	1.34	1.13	0.89	1.45	1.22	0.96
	SAT	15.2	13.8	12.0	15.3	13.8	12.0	15.4	13.8	12.0	15.4	13.8	12.0	15.4	13.9	12.0	15.5	13.9	12.0
	WF	127	99	79	154	122	95	203	162	127	224	179	141	243	195	153	260	210	165

Entering / leaving water temperature, °C		42NH & NL 335 / 339																	
		Relative humidity 50%																	
		Air flow, m³/h (l/s)																	
		300 (83)			350 (97)			450 (125)			550 (153)			600 (167)			700 (194)		
		Entering air dry-bulb temperature, °C																	
		27	25	23	27	25	23	27	25	23	27	25	23	27	25	23			
6-12	TC	1.93	1.52	1.16	2.18	1.71	1.32	2.63	2.07	1.60	3.03	2.40	1.87	3.22	2.55	2.00	3.56	2.82	2.24
	SHC	1.40	1.23	1.07	1.59	1.40	1.22	1.95	1.72	1.50	2.28	2.02	1.77	2.44	2.16	1.89	2.73	2.42	2.13
	SAT	12.3	12.0	11.4	12.5	12.1	11.5	12.9	12.3	11.6	13.2	12.5	11.6	13.3	12.6	11.7	13.5	12.7	11.7
	WF	282	221	169	318	249	192	384	302	234	442	349	273	469	371	291	518	411	326
10-15	TC	1.31	1.02	0.81	1.48	1.16	0.92	1.80	1.42	1.13	2.08	1.67	1.33	2.22	1.78	1.42	2.46	2.00	1.60
	SHC	1.14	0.99	0.81	1.30	1.13	0.92	1.60	1.39	1.13	1.88	1.63	1.33	2.01	1.74	1.42	2.26	1.96	1.60
	SAT	14.7	13.6	12.0	14.8	13.7	12.0	14.9	13.7	12.0	15.0	13.7	12.0	15.1	13.7	12.0	15.2	13.8	12.0
	WF	226	176	140	256	200	159	310	245	195	359	287	229	382	307	245	424	344	276

Entering / leaving water temperature, °C		42NH & NL 435 / 439																	
		Relative humidity 50%																	
		Air flow, m³/h (l/s)																	
		450 (125)			550 (153)			750 (208)			850 (236)			950 (264)			1050 (292)		
		Entering air dry-bulb temperature, °C																	
		27	25	23	27	25	23	27	25	23	27	25	23	27	25	23			
6-12	TC	2.64	2.06	1.61	3.13	2.45	1.92	3.98	3.14	2.47	4.35	3.44	2.72	4.68	3.72	2.96	4.98	3.97	3.17
	SHC	1.98	1.74	1.51	2.36	2.08	1.80	3.05	2.71	2.35	3.37	2.99	2.60	3.66	3.26	2.83	3.93	3.51	3.05
	SAT	12.9	12.4	11.5	13.1	12.5	11.6	13.4	12.7	11.7	13.6	12.8	11.7	13.7	12.9	11.7	13.9	13.0	11.8
	WF	385	301	235	456	357	279	580	458	360	634	501	397	682	542	431	726	579	462
10-15	TC	1.82	1.40	1.12	2.16	1.67	1.34	2.77	2.18	1.75	3.04	2.40	1.93	3.28	2.62	2.11	3.50	2.82	2.27
	SHC	1.63	1.39	1.12	1.94	1.66	1.34	2.52	2.16	1.75	2.79	2.39	1.93	3.04	2.61	2.11	3.27	2.81	2.27
	SAT	14.9	13.8	12.0	15.0	13.8	12.0	15.1	13.8	12.0	15.2	13.8	12.0	15.2	13.8	12.0	15.3	13.8	12.0
	WF	313	242	193	372	288	231	477	375	301	524	414	333	566	451	363	604	485	391

Entering / leaving water temperature, °C		42NH & NL 535 / 539																	
		Relative humidity 50%																	
		Air flow, m³/h (l/s)																	
		550 (153)			650 (181)			850 (236)			1000 (278)			1150 (319)			1300 (361)		
		Entering air dry-bulb temperature, °C																	
		27	25	23	27	25	23	27	25	23	27	25	23	27	25	23			
6-12	TC	3.00	2.34	1.81	3.46	2.70	2.10	4.29	3.37	2.64	4.82	3.81	2.99	5.28	4.19	3.32	5.69	4.53	3.62
	SHC	2.28	2.00	1.73	2.64	2.32	2.00	3.30	2.91	2.53	3.74	3.31	2.88	4.15	3.68	3.20	4.52	4.01	3.51
	SAT	13.3	12.6	11.7	13.4	12.7	11.7	13.6	12.8	11.7	13.7	12.9	11.8	13.9	13.0	11.8	14.1	13.1	11.8
	WF	437	341	264	504	394	306	626	491	384	702	555	437	770	611	484	829	660	528
10-15	TC	2.06	1.63	1.29	2.39	1.89	1.50	2.97	2.37	1.89	3.36	2.69	2.15	3.70	3.00	2.39	4.01	3.27	2.61
	SHC	1.87	1.60	1.29	2.17	1.86	1.50	2.73	2.34	1.89	3.11	2.67	2.15	3.45	2.97	2.39	3.77	3.25	2.61
	SAT	15.1	13.8	12.0	15.1	13.8	12.0	15.2	13.8	12.0	15.2	13.8	12.0	15.3	13.8	12.0	15.4	13.8	12.0
	WF	356	280	222	411	325	258	512	408	325	579	464	370	637	516	412	691	563	450

Legend:

TC Total cooling capacity (kW)
 SHC Sensible cooling capacity (kW)
 SAT Supply air temperature (°C)
 WF Water flow rate (l/h)

NOTE:

- To convert l/h to l/s, divide by 3600.
- Operating limits - air discharge temperature 12°C when the unit is installed in an ambient temperature of 27°C dry bulb and 65% relative humidity.

7.8.2 - Cooling capacity 4-pipe water coil (continued)

Entering / leaving water temperature, °C		42NH & NL 545 / 549																	
		Relative humidity 50%																	
		Air flow, m³/h (l/s)																	
		550 (153)			650 (181)			850 (236)			1000 (278)			1150 (319)			1300 (361)		
		Entering air dry-bulb temperature, °C																	
		27	25	23	27	25	23	27	25	23	27	25	23	27	25	23			
6-12	TC	3.25	2.53	1.96	3.79	2.96	2.30	4.82	3.77	2.95	5.48	4.34	3.40	6.10	4.85	3.83	6.65	5.30	4.22
	SHC	2.43	2.14	1.85	2.85	2.50	2.17	3.63	3.20	2.78	4.17	3.70	3.22	4.68	4.16	3.63	5.15	4.59	4.01
	SAT	12.9	12.5	11.6	13.0	12.5	11.6	13.1	12.5	11.6	13.3	12.6	11.6	13.4	12.7	11.7	13.6	12.8	11.7
	WF	473	368	286	553	431	336	702	550	430	799	632	496	888	706	558	969	773	615
10-15	TC	2.23	1.75	1.38	2.61	2.05	1.63	3.33	2.62	2.09	3.82	3.03	2.42	4.26	3.41	2.73	4.67	3.76	3.01
	SHC	2.00	1.72	1.38	2.35	2.02	1.63	3.00	2.59	2.09	3.46	2.99	2.42	3.89	3.37	2.73	4.29	3.72	3.01
	SAT	15.0	13.8	12.0	15.0	13.8	12.0	15.0	13.8	12.0	15.1	13.8	12.0	15.1	13.8	12.0	15.2	13.8	12.0
	WF	385	301	238	450	353	281	573	452	361	657	521	417	734	587	470	805	647	519

Entering / leaving water temperature, °C		42NH 645 / 649																	
		Relative humidity 50%																	
		Air flow, m³/h (l/s)																	
		700 (194)			1100 (306)			1450 (403)			1650 (458)			1800 (500)			2000 (556)		
		Entering air dry-bulb temperature, °C																	
		27	25	23	27	25	23	27	25	23	27	25	23	27	25	23			
6-12	TC	4.14	3.20	2.48	6.10	4.74	3.71	7.40	5.78	4.56	7.96	6.24	4.97	8.35	6.57	5.24	8.83	7.00	5.60
	SHC	3.12	2.74	2.38	4.66	4.10	3.58	5.78	5.11	4.45	6.32	5.59	4.87	6.70	5.95	5.17	7.19	6.40	5.55
	SAT	13.0	12.5	11.7	13.3	12.7	11.8	13.6	12.9	11.9	13.9	13.1	11.9	14.0	13.2	11.9	14.2	13.3	12.0
	WF	603	467	361	889	690	541	1077	842	664	1160	910	723	1216	957	764	1285	1019	816
10-15	TC	2.73	2.24	1.78	4.23	3.35	2.67	5.17	4.15	3.30	5.61	4.53	3.61	5.91	4.80	3.81	6.30	5.14	4.07
	SHC	2.63	2.23	1.78	3.87	3.34	2.67	4.82	4.14	3.30	5.29	4.53	3.61	5.63	4.80	3.81	6.05	5.14	4.07
	SAT	14.5	13.8	12.0	15.1	13.8	12.0	15.3	13.8	12.0	15.4	13.9	12.0	15.4	13.9	12.0	15.5	13.8	12.0
	WF	471	385	306	728	577	460	891	714	569	965	780	621	1018	827	657	1084	885	702

Entering / leaving water temperature, °C		42NH 735 / 739																	
		Relative humidity 50%																	
		Air flow, m³/h (l/s)																	
		550 (153)			800 (222)			1350 (375)			1950 (542)			2200 (611)			2400 (667)		
		Entering air dry-bulb temperature, °C																	
		27	25	23	27	25	23	27	25	23	27	25	23	27	25	23			
6-12	TC	3.26	2.55	1.97	4.56	3.58	2.79	7.09	5.63	4.46	9.34	7.51	6.02	10.16	8.20	6.60	10.78	8.72	7.05
	SHC	2.44	2.15	1.85	3.43	3.03	2.63	5.42	4.82	4.21	7.31	6.52	5.72	8.01	7.18	6.29	8.57	7.68	6.74
	SAT	12.9	12.4	11.6	13.1	12.5	11.6	13.4	12.7	11.6	13.8	12.9	11.7	13.9	12.9	11.7	14.0	13.0	11.7
	WF	475	372	287	664	522	407	1032	821	650	1361	1094	877	1479	1195	961	1571	1270	1027
10-15	TC	2.16	1.77	1.37	3.15	2.49	1.95	4.95	3.96	3.14	6.59	5.36	4.28	7.19	5.88	4.70	7.69	6.26	5.02
	SHC	2.04	1.72	1.37	2.83	2.43	1.95	4.49	3.88	3.14	6.09	5.26	4.28	6.69	5.78	4.70	7.18	6.16	5.02
	SAT	14.3	13.7	12.0	15.0	13.7	12.0	15.1	13.7	12.0	15.2	13.8	12.0	15.3	13.8	12.0	15.3	13.8	12.0
	WF	371	305	235	542	429	337	852	683	541	1134	924	736	1238	1012	809	1324	1077	864

Entering / leaving water temperature, °C		42NH 745 / 749																	
		Relative humidity 50%																	
		Air flow, m³/h (l/s)																	
		550 (153)			800 (222)			1350 (375)			1950 (542)			2200 (611)			2400 (667)		
		Entering air dry-bulb temperature, °C																	
		27	25	23	27	25	23	27	25	23	27	25	23	27	25	23			
6-12	TC	3.92	3.07	2.37	5.73	4.53	3.51	9.21	7.33	5.74	11.88	9.49	7.54	12.71	10.17	8.10	13.32	10.69	8.54
	SHC	2.76	2.42	2.11	4.02	3.54	3.09	6.53	5.79	5.08	8.69	7.74	6.85	9.44	8.43	7.46	10.01	8.96	7.92
	SAT	11.6	11.5	11.0	11.5	11.3	10.9	11.9	11.5	11.0	12.6	12.1	11.3	12.9	12.3	11.4	13.1	12.4	11.5
	WF	571	447	345	835	659	511	1342	1068	836	1730	1382	1098	1851	1482	1180	1941	1556	1245
10-15	TC	2.53	2.06	1.63	3.94	3.03	2.40	6.36	4.95	3.95	8.23	6.57	5.29	8.84	7.22	5.74	9.31	7.47	6.07
	SHC	2.28	1.96	1.63	3.27	2.85	2.40	5.34	4.68	3.94	7.18	6.32	5.29	7.83	6.85	5.74	8.33	7.28	6.07
	SAT	13.9	13.5	12.0	14.2	13.4	12.0	14.3	13.5	12.0	14.7	13.6	12.0	14.9	11.5	12.0	15.0	13.7	12.0
	WF	436	355	281	677	522	413	1096	852	679	1417	1131	911	1522	1211	989	1602	1286	1045

Legend:

- TC Total cooling capacity (kW)
- SHC Sensible cooling capacity (kW)
- SAT Supply air temperature (°C)
- WF Water flow rate (l/h)

NOTE:

- To convert l/h to l/s, divide by 3600.
- Operating limits - air discharge temperature 12°C when the unit is installed in an ambient temperature of 27°C dry bulb and 65% relative humidity.

7.8.3 - Heating capacity 2-pipe water coil

Entering / leaving water temperature, °C		42NH & NL 225 / 229																	
		Air flow, m³/h (l/s)																	
		200 (56)			250 (69)			350 (97)			400 (111)			450 (125)			500 (139)		
		Entering air dry-bulb temperature, °C																	
		21	20	19	21	20	19	21	20	19	21	20	19	21	20	19	21	20	19
50-45	HC	1.61	1.68	1.75	1.96	2.04	2.12	2.59	2.70	2.80	2.86	2.98	3.10	3.11	3.24	3.37	3.34	3.48	3.62
	SAT	45.0	44.9	44.8	44.3	44.2	44.1	43.0	42.9	42.7	42.3	42.1	41.9	41.6	41.4	41.2	40.9	40.7	40.4
	WF	281	292	304	341	356	370	450	469	488	498	519	540	542	564	587	581	606	630
40-35	HC	0.97	1.04	1.10	1.18	1.26	1.34	1.55	1.66	1.76	1.71	1.83	1.95	1.86	1.99	2.11	1.99	2.13	2.27
	SAT	35.5	35.4	35.3	35.1	35.0	34.9	34.2	34.1	33.9	33.7	33.6	33.4	33.3	33.1	32.9	32.9	32.6	32.4
	WF	169	180	192	205	219	233	269	288	306	297	317	338	322	344	367	345	369	393

Entering / leaving water temperature, °C		42NH & NL 235 / 239 / 279																	
		Air flow, m³/h (l/s)																	
		200 (56)			250 (69)			350 (97)			400 (111)			450 (125)			500 (139)		
		Entering air dry-bulb temperature, °C																	
		21	20	19	21	20	19	21	20	19	21	20	19	21	20	19	21	20	19
50-45	HC	1.74	1.82	1.89	2.14	2.23	2.32	2.89	3.01	3.13	3.23	3.36	3.50	3.55	3.70	3.85	3.85	4.02	4.18
	SAT	47.0	47.0	46.9	46.5	46.5	46.5	45.6	45.5	45.4	45.0	45.0	44.9	44.5	44.4	44.3	44.0	43.8	43.7
	WF	304	316	329	373	389	404	503	524	545	562	586	609	618	644	670	671	699	727
40-35	HC	1.06	1.14	1.21	1.30	1.39	1.48	1.75	1.87	1.98	1.95	2.08	2.21	2.14	2.28	2.43	2.31	2.47	2.63
	SAT	36.8	36.8	36.8	36.5	36.5	36.5	35.9	35.8	35.8	35.5	35.4	35.4	35.1	35.1	35.0	34.8	34.7	34.6
	WF	184	197	209	226	241	257	303	324	344	338	361	384	371	396	421	402	429	456

Entering / leaving water temperature, °C		42NH & NL 325 / 329																	
		Air flow, m³/h (l/s)																	
		300 (83)			350 (97)			450 (125)			550 (153)			600 (167)			700 (194)		
		Entering air dry-bulb temperature, °C																	
		21	20	19	21	20	19	21	20	19	21	20	19	21	20	19	21	20	19
50-45	HC	2.33	2.43	2.52	2.64	2.75	2.86	3.20	3.34	3.47	3.68	3.83	3.99	3.89	4.05	4.22	4.26	4.44	4.62
	SAT	44.1	44.0	43.9	43.4	43.3	43.2	42.2	42.0	41.8	40.9	40.7	40.5	40.3	40.0	39.8	39.1	38.8	38.5
	WF	405	422	439	459	479	499	557	581	605	640	667	695	676	705	734	741	773	805
40-35	HC	1.39	1.49	1.58	1.57	1.68	1.79	1.90	2.03	2.16	2.17	2.32	2.48	2.29	2.45	2.61	2.50	2.67	2.85
	SAT	34.8	34.7	34.6	34.4	34.3	34.1	33.6	33.4	33.2	32.7	32.5	32.3	32.4	32.1	31.9	31.6	31.3	31.0
	WF	241	258	274	273	292	311	329	352	375	376	403	429	397	425	453	433	464	495

Entering / leaving water temperature, °C		42NH & NL 335 / 339																	
		Air flow, m³/h (l/s)																	
		300 (83)			350 (97)			450 (125)			550 (153)			600 (167)			700 (194)		
		Entering air dry-bulb temperature, °C																	
		21	20	19	21	20	19	21	20	19	21	20	19	21	20	19	21	20	19
50-45	HC	2.62	2.73	2.84	3.02	3.15	3.27	3.77	3.93	4.09	4.44	4.63	4.81	4.74	4.94	5.14	5.29	5.51	5.74
	SAT	47.0	47.0	47.0	46.7	46.7	46.7	45.9	45.9	45.9	45.0	45.0	44.9	44.5	44.4	44.4	43.5	43.4	43.2
	WF	457	476	495	526	548	570	656	683	711	773	805	838	826	860	896	921	960	999
40-35	HC	1.60	1.70	1.81	1.83	1.96	2.08	2.27	2.43	2.59	2.67	2.85	3.03	2.84	3.04	3.23	3.15	3.37	3.59
	SAT	36.8	36.9	36.9	36.6	36.6	36.6	36.1	36.0	36.0	35.4	35.4	35.3	35.1	35.0	34.9	34.4	34.3	34.2
	WF	277	296	314	318	340	361	395	422	449	462	494	526	493	527	561	547	585	623

Entering / leaving water temperature, °C		42NH & NL 425 / 429																	
		Air flow, m³/h (l/s)																	
		450 (125)			550 (153)			750 (208)			850 (236)			950 (264)			1050 (292)		
		Entering air dry-bulb temperature, °C																	
		21	20	19	21	20	19	21	20	19	21	20	19	21	20	19	21	20	19
50-45	HC	3.40	3.55	3.69	4.14	4.31	4.49	5.48	5.71	5.94	6.08	6.34	6.59	6.62	6.90	7.18	7.11	7.41	7.71
	SAT	43.5	43.4	43.3	43.4	43.3	43.1	42.8	42.6	42.4	42.3	42.1	41.9	41.8	41.6	41.4	41.2	40.9	40.7
	WF	593	618	643	721	751	781	954	994	1035	1058	1103	1148	1153	1201	1250	1237	1289	1342
40-35	HC	2.03	2.17	2.31	2.47	2.64	2.81	3.27	3.50	3.73	3.63	3.88	4.13	3.94	4.22	4.49	4.22	4.52	4.81
	SAT	34.4	34.3	34.2	34.4	34.3	34.1	34.0	33.8	33.7	33.7	33.5	33.4	33.4	33.2	33.0	33.0	32.8	32.5
	WF	352	377	401	429	458	488	568	607	646	629	672	716	684	731	779	733	783	834

Entering / leaving water temperature, °C		42NH & NL 435 / 439																	
		Air flow, m³/h (l/s)																	
		450 (125)			550 (153)			750 (208)			850 (236)			950 (264)			1050 (292)		
		Entering air dry-bulb temperature, °C																	
		21	20	19	21	20	19	21	20	19	21	20	19	21	20	19	21	20	19
50-45	HC	3.87	4.04	4.20	4.73	4.93	5.13	6.41	6.68	6.94	7.22	7.52	7.82	8.00	8.33	8.66	8.75	9.12	9.48
	SAT	46.6	46.6	46.6	46.6	46.6	46.6	46.4	46.4	46.4	46.3	46.2	46.2	46.1	46.0	46.0	45.8	45.8	45.7
	WF	674	702	730	824	858	892	1115	1162	1208	1256	1308	1361	1393	1450	1508	1525	1587	1651
40-35	HC	2.36	2.52	2.68	2.89	3.08	3.28	3.91	4.18	4.44	4.41	4.70	4.99	4.88	5.21	5.53	5.33	5.69	6.05
	SAT	36.6	36.6	36.6	36.6	36.6	36.6	36.5	36.5	36.5	36.4	36.4	36.4	36.3	36.3	36.2	36.1	36.1	36.0
	WF	410	437	465	501	535	568	679	724	769	764	815	866	846	903	959	925	987	1049

Legend:

- HC Heating capacity (kW)
- SAT Supply air temperature (°C)
- WF Water flow rate (l/h)

NOTE:

- To convert l/h to l/s, divide by 3600.
- The supply air temperature should be kept below 35°C in order to avoid the risk of stratification.

7.8.3 - Heating capacity 2-pipe water coil (continued)

Entering / leaving water temperature, °C		42NH & NL 525 / 529																	
		Air flow, m³/h (l/s)																	
		550 (153)			650 (181)			850 (236)			1000 (278)			1150 (319)			1300 (361)		
		Entering air dry-bulb temperature, °C																	
		21	20	19	21	20	19	21	20	19	21	20	19	21	20	19	21	20	19
50-45	HC	4.17	4.34	4.52	4.85	5.06	5.26	6.09	6.35	6.60	6.89	7.18	7.47	7.56	7.88	8.20	8.15	8.49	8.83
	SAT	43.6	43.4	43.3	43.2	43.1	42.9	42.3	42.2	42.0	41.5	41.3	41.1	40.6	40.3	40.1	39.7	39.4	39.1
	WF	725	756	786	845	880	916	1061	1105	1150	1199	1249	1300	1317	1372	1428	1418	1478	1537
40-35	HC	2.50	2.67	2.84	2.91	3.11	3.31	3.65	3.90	4.15	4.11	4.40	4.68	4.50	4.82	5.13	4.84	5.17	5.51
	SAT	34.5	34.4	34.3	34.3	34.2	34.1	33.8	33.6	33.4	33.2	33.0	32.8	32.7	32.4	32.2	32.1	31.8	31.5
	WF	434	463	493	505	540	574	632	676	719	714	762	811	781	835	889	839	897	955

Entering / leaving water temperature, °C		42NH & NL 535 / 539																	
		Air flow, m³/h (l/s)																	
		550 (153)			650 (181)			850 (236)			1000 (278)			1150 (319)			1300 (361)		
		Entering air dry-bulb temperature, °C																	
		21	20	19	21	20	19	21	20	19	21	20	19	21	20	19	21	20	19
50-45	HC	4.72	4.92	5.12	5.58	5.82	6.05	7.18	7.48	7.78	8.23	8.57	8.92	9.15	9.53	9.91	9.92	10.33	10.75
	SAT	46.6	46.5	46.5	46.6	46.5	46.5	46.1	46.1	46.0	45.5	45.4	45.4	44.7	44.6	44.5	43.7	43.6	43.5
	WF	822	856	890	972	1012	1052	1250	1301	1353	1433	1493	1553	1592	1658	1725	1727	1799	1872
40-35	HC	2.88	3.07	3.26	3.41	3.63	3.86	4.37	4.66	4.96	5.00	5.33	5.67	5.52	5.90	6.27	5.96	6.37	6.77
	SAT	36.6	36.6	36.5	36.6	36.6	36.6	36.3	36.3	36.2	35.9	35.8	35.8	35.3	35.2	35.1	34.6	34.5	34.4
	WF	499	533	566	591	630	670	759	809	860	867	925	983	958	1023	1088	1034	1104	1175

Entering / leaving water temperature, °C		42NH 635 / 649																	
		Air flow, m³/h (l/s)																	
		700 (194)			1100 (306)			1450 (403)			1650 (458)			1800 (500)			2000 (556)		
		Entering air dry-bulb temperature, °C																	
		21	20	19	21	20	19	21	20	19	21	20	19	21	20	19	21	20	19
50-45	HC	5.99	6.24	6.49	9.18	9.57	9.95	11.70	12.19	12.69	12.99	13.53	14.08	13.86	14.45	15.03	14.91	15.53	16.16
	SAT	46.5	46.4	46.4	45.8	45.8	45.7	45.0	44.9	44.9	44.4	44.3	44.2	43.9	43.8	43.7	43.2	43.0	42.9
	WF	1045	1088	1132	1602	1668	1735	2042	2127	2212	2266	2361	2456	2420	2520	2622	2601	2710	2820
40-35	HC	3.64	3.89	4.13	5.57	5.95	6.32	7.08	7.56	8.03	7.83	8.36	8.89	8.34	8.91	9.47	8.93	9.54	10.16
	SAT	36.5	36.5	36.5	36.1	36.0	36.0	35.5	35.5	35.4	35.1	35.0	34.9	34.8	34.7	34.6	34.3	34.2	34.0
	WF	633	675	718	968	1034	1099	1230	1313	1396	1361	1453	1545	1449	1547	1646	1552	1658	1765

Entering / leaving water temperature, °C		42NH 645 / 649																	
		Air flow, m³/h (l/s)																	
		700 (194)			1100 (306)			1450 (403)			1650 (458)			1800 (500)			2000 (556)		
		Entering air dry-bulb temperature, °C																	
		21	20	19	21	20	19	21	20	19	21	20	19	21	20	19	21	20	19
50-45	HC	6.48	6.61	6.87	9.60	10.29	10.69	12.70	13.17	13.70	14.18	14.62	15.20	15.13	15.60	16.24	16.38	16.84	17.52
	SAT	48.5	48.0	48.0	47.0	47.7	47.7	47.1	46.9	46.9	46.6	46.3	46.2	46.0	45.7	45.7	45.4	45.0	44.9
	WF	1129	1154	1199	1675	1795	1865	2215	2297	2388	2474	2550	2651	2641	2722	2831	2858	2938	3056
40-35	HC	3.92	4.17	4.43	5.85	6.49	6.89	7.77	8.25	8.76	8.64	9.10	9.68	9.18	9.68	10.30	9.89	10.40	11.07
	SAT	37.7	37.7	37.7	36.8	37.5	37.5	37.0	36.9	36.9	36.6	36.4	36.3	36.2	36.0	35.9	35.7	35.4	35.4
	WF	681	724	769	1017	1127	1196	1350	1433	1522	1502	1582	1682	1595	1682	1789	1719	1807	1923

Entering / leaving water temperature, °C		42NH & NL 735 / 739																	
		Air flow, m³/h (l/s)																	
		550 (153)			800 (222)			1350 (375)			1950 (542)			2200 (611)			2400 (667)		
		Entering air dry-bulb temperature, °C																	
		21	20	19	21	20	19	21	20	19	21	20	19	21	20	19	21	20	19
50-45	HC	4.63	4.82	5.01	6.57	6.84	7.11	10.72	11.16	11.60	15.00	15.62	16.24	16.66	17.35	18.04	17.90	18.65	19.40
	SAT	46.1	46.0	45.9	45.4	45.4	45.3	44.6	44.5	44.4	43.9	43.8	43.6	43.5	43.4	43.2	43.2	43.1	42.9
	WF	807	841	874	1146	1193	1240	1869	1947	2024	2617	2725	2834	2907	3027	3147	3126	3254	3384
40-35	HC	2.81	3.00	3.19	3.99	4.26	4.52	6.51	6.94	7.38	9.10	9.71	10.32	10.10	10.77	11.45	10.85	11.57	12.30
	SAT	36.2	36.2	36.2	35.9	35.8	35.7	35.3	35.3	35.2	34.9	34.8	34.6	34.7	34.5	34.4	34.5	34.3	34.2
	WF	488	521	554	694	740	786	1130	1206	1282	1581	1686	1792	1755	1872	1989	1884	2010	2137

Entering / leaving water temperature, °C		42NH & NL 745 / 749																	
		Air flow, m³/h (l/s)																	
		550 (153)			800 (222)			1350 (375)			1950 (542)			2200 (611)			2400 (667)		
		Entering air dry-bulb temperature, °C																	
		21	20	19	21	20	19	21	20	19	21	20	19	21	20	19	21	20	19
50-45	HC	4.68	4.88	5.07	6.75	7.04	7.32	11.29	11.76	12.22	16.01	16.66	17.33	17.82	18.55	19.29	19.17	19.96	20.76
	SAT	46.3	46.3	46.3	46.1	46.1	46.0	45.9	45.8	45.8	45.4	45.4	45.3	45.1	45.0	44.9	44.8	44.7	44.6
	WF	817	850	884	1179	1227	1276	1969	2050	2132	2792	2907	3022	3109	3237	3366	3346	3482	3621
40-35	HC	2.81	3.00	3.20	4.10	4.38	4.65	6.88	7.34	7.80	9.76	10.41	11.05	10.85	11.57	12.29	11.66	12.43	13.21
	SAT	36.2	36.2	36.2	36.2	36.2	36.2	36.2	36.1	36.1	35.9	35.8	35.8	35.7	35.6	35.5	35.5	35.4	35.3
	WF	488	522	556	712	760	809	1196	1276	1355	1696	1808	1920	1886	2011	2136	2025	2160	2295

Legend:

- HC Heating capacity (kW)
- SAT Supply air temperature (°C)
- WF Water flow rate (l/h)

NOTE:

- To convert l/h to l/s, divide by 3600.
- The supply air temperature should be kept below 35°C in order to avoid the risk of stratification.

7.8.4 - Heating capacity 4-pipe water coil

Entering / leaving water temperature, °C		42NH & NL 235 / 239 / 279																	
		Air flow, m ³ /h (l/s)																	
		200 (56)			250 (69)			350 (97)			400 (111)			450 (125)			500 (139)		
		Entering air dry-bulb temperature, °C																	
		21	20	19	21	20	19	21	20	19	21	20	19	21	20	19	21	20	19
60-50	HC	1.28	1.33	1.37	1.54	1.59	1.65	1.96	2.03	2.11	2.14	2.21	2.29	2.28	2.36	2.45	2.41	2.49	2.58
	SAT	40.1	39.7	39.3	39.3	38.9	38.5	37.7	37.2	36.8	36.9	36.4	35.9	36.1	35.6	35.1	35.3	34.8	34.3
	WF	112	116	119	134	139	143	171	177	183	186	193	199	199	206	213	210	217	225
50-40	HC	0.82	0.87	0.92	1.00	1.05	1.11	1.28	1.35	1.42	1.39	1.47	1.54	1.49	1.56	1.64	1.56	1.65	1.73
	SAT	33.3	32.9	32.5	32.9	32.5	32.1	31.9	31.5	31.0	31.4	30.9	30.4	30.8	30.3	29.8	30.3	29.8	29.2
	WF	72	76	80	87	91	96	111	118	124	121	128	134	129	136	143	136	143	150

Entering / leaving water temperature, °C		42NH & NL 335 / 339																	
		Air flow, m ³ /h (l/s)																	
		300 (83)			350 (97)			450 (125)			550 (153)			600 (167)			700 (194)		
		Entering air dry-bulb temperature, °C																	
		21	20	19	21	20	19	21	20	19	21	20	19	21	20	19	21	20	19
60-50	HC	2.02	2.09	2.16	2.27	2.35	2.43	2.68	2.77	2.86	2.99	3.09	3.19	3.12	3.23	3.34	3.39	3.51	3.62
	SAT	41.1	40.7	40.3	40.3	39.9	39.5	38.7	38.3	37.8	37.2	36.7	36.2	36.5	36.0	35.4	35.4	34.9	34.3
	WF	176	182	188	198	205	211	233	241	250	260	269	278	272	281	291	295	305	316
50-40	HC	1.36	1.43	1.49	1.52	1.60	1.67	1.79	1.88	1.97	1.98	2.08	2.19	2.07	2.17	2.28	2.24	2.35	2.47
	SAT	34.5	34.1	33.7	33.9	33.5	33.1	32.8	32.4	31.9	31.7	31.2	30.8	31.2	30.7	30.2	30.5	30.0	29.4
	WF	118	124	130	132	139	145	155	163	171	172	181	190	179	189	198	194	204	214

Entering / leaving water temperature, °C		42NH & NL 435 / 439																	
		Air flow, m ³ /h (l/s)																	
		450 (125)			550 (153)			750 (208)			850 (236)			950 (264)			1050 (292)		
		Entering air dry-bulb temperature, °C																	
		21	20	19	21	20	19	21	20	19	21	20	19	21	20	19	21	20	19
60-50	HC	2.56	2.65	2.73	3.14	3.25	3.36	4.18	4.32	4.46	4.62	4.78	4.94	5.01	5.18	5.35	5.35	5.53	5.71
	SAT	37.9	37.4	37.0	38.0	37.5	37.0	37.6	37.1	36.6	37.2	36.7	36.2	36.7	36.2	35.7	36.2	35.6	35.1
	WF	223	230	238	274	283	292	364	376	389	402	416	430	436	451	466	466	482	498
50-40	HC	1.71	1.80	1.88	2.11	2.21	2.32	2.81	2.95	3.09	3.11	3.26	3.42	3.37	3.53	3.70	3.59	3.77	3.95
	SAT	32.3	31.8	31.4	32.4	31.9	31.5	32.1	31.7	31.2	31.9	31.4	30.9	31.6	31.0	30.5	31.2	30.7	30.1
	WF	148	156	163	183	192	201	244	256	268	270	283	297	292	307	322	312	327	343

Entering / leaving water temperature, °C		42NH & NL 535 / 539																	
		Air flow, m ³ /h (l/s)																	
		550 (153)			650 (181)			850 (236)			1000 (278)			1150 (319)			1300 (361)		
		Entering air dry-bulb temperature, °C																	
		21	20	19	21	20	19	21	20	19	21	20	19	21	20	19	21	20	19
60-50	HC	2.48	2.57	2.67	2.82	2.93	3.03	3.42	3.54	3.67	3.79	3.92	4.06	4.10	4.25	4.40	4.37	4.53	4.69
	SAT	34.4	33.9	33.3	33.9	33.4	32.8	33.0	32.4	31.8	32.3	31.6	31.0	31.6	31.0	30.3	31.0	30.3	29.7
	WF	216	224	232	246	255	264	298	308	319	330	342	354	357	370	383	380	394	408
50-40	HC	1.52	1.61	1.71	1.75	1.85	1.96	2.14	2.27	2.40	2.38	2.53	2.67	2.59	2.74	2.89	2.76	2.92	3.07
	SAT	29.2	28.7	28.2	29.0	28.5	27.9	28.5	27.9	27.3	28.1	27.5	26.9	27.7	27.1	26.4	27.3	26.7	26.0
	WF	132	140	148	152	161	170	186	197	208	207	220	232	225	238	251	240	253	267

Legend:

HC Heating capacity (kW)
 SAT Supply air temperature (°C)
 WF Water flow rate (l/h)

NOTE:

- To convert l/h to l/s, divide by 3600.
- The supply air temperature should be kept below 35°C in order to avoid the risk of stratification.

7.8.4 - Heating capacity 4-pipe water coil (continued)

Entering / leaving water temperature, °C		42NH & NL 545 / 549																	
		Air flow, m ³ /h (l/s)																	
		550 (153)			650 (181)			850 (236)			1000 (278)			1150 (319)			1300 (361)		
		Entering air dry-bulb temperature, °C																	
		21	20	19	21	20	19	21	20	19	21	20	19	21	20	19	21	20	19
60-50	HC	2.95	3.06	3.17	3.44	3.56	3.69	4.26	4.41	4.57	4.73	4.90	5.08	5.08	5.27	5.46	5.35	5.54	5.74
	SAT	37.0	36.5	36.0	36.7	36.3	35.8	35.9	35.4	34.9	35.1	34.5	34.0	34.2	33.6	33.0	33.2	32.7	32.1
	WF	257	266	276	299	310	322	371	384	398	412	427	442	443	459	476	466	483	500
50-40	HC	1.78	1.89	2.01	2.11	2.24	2.37	2.67	2.83	2.99	2.98	3.16	3.33	3.21	3.40	3.58	3.37	3.57	3.76
	SAT	30.6	30.2	29.8	30.7	30.2	29.8	30.3	29.9	29.4	29.9	29.4	28.9	29.3	28.8	28.2	28.7	28.1	27.5
	WF	155	164	174	183	195	206	232	246	260	259	274	290	279	295	311	293	310	326

Entering / leaving water temperature, °C		42NH 645 / 649																	
		Air flow, m ³ /h (l/s)																	
		700 (194)			1100 (306)			1450 (403)			1650 (458)			1800 (500)			2000 (556)		
		Entering air dry-bulb temperature, °C																	
		21	20	19	21	20	19	21	20	19	21	20	19	21	20	19	21	20	19
60-50	HC	3.93	4.07	4.22	5.67	5.88	6.08	6.64	6.88	7.12	6.99	7.25	7.51	7.21	7.47	7.74	7.48	7.76	8.04
	SAT	37.7	37.3	36.8	36.3	35.8	35.4	34.6	34.1	33.5	33.6	33.0	32.5	32.9	32.3	31.7	32.1	31.5	30.9
	WF	344	356	369	496	514	533	581	602	624	612	635	657	631	654	678	655	679	704
50-40	HC	2.42	2.57	2.71	3.60	3.81	4.02	4.22	4.46	4.70	4.44	4.69	4.93	4.56	4.82	5.07	4.71	4.98	5.25
	SAT	31.3	30.9	30.5	30.7	30.3	29.8	29.7	29.1	28.6	29.0	28.4	27.8	28.5	27.9	27.3	28.0	27.4	26.8
	WF	211	224	237	314	332	351	368	389	410	387	409	430	397	420	442	411	434	458

Entering / leaving water temperature, °C		42NH 735 / 739																	
		Air flow, m ³ /h (l/s)																	
		550 (153)			800 (222)			1350 (375)			1950 (542)			2200 (611)			2400 (667)		
		Entering air dry-bulb temperature, °C																	
		21	20	19	21	20	19	21	20	19	21	20	19	21	20	19	21	20	19
60-50	HC	3.09	3.20	3.31	4.38	4.53	4.69	7.00	7.25	7.50	9.36	9.69	10.02	10.17	10.53	10.88	10.75	11.12	11.50
	SAT	37.7	37.3	36.8	37.3	36.8	36.3	36.4	35.9	35.4	35.3	34.7	34.2	34.8	34.2	33.6	34.3	33.7	33.2
	WF	270	280	290	384	397	411	613	635	656	820	848	877	891	922	953	941	973	1006
50-40	HC	1.96	2.08	2.19	2.86	3.01	3.17	4.63	4.87	5.11	6.19	6.51	6.83	6.73	7.07	7.42	7.10	7.47	7.83
	SAT	31.6	31.2	30.8	31.6	31.2	30.7	31.2	30.7	30.2	30.5	29.9	29.4	30.1	29.5	29.0	29.8	29.2	28.6
	WF	171	181	191	249	263	277	404	424	445	540	568	596	587	617	647	619	651	683

Entering / leaving water temperature, °C		42NH 745 / 749																	
		Air flow, m ³ /h (l/s)																	
		550 (153)			800 (222)			1350 (375)			1950 (542)			2200 (611)			2400 (667)		
		Entering air dry-bulb temperature, °C																	
		21	20	19	21	20	19	21	20	19	21	20	19	21	20	19	21	20	19
60-50	HC	3.53	3.66	3.79	5.32	5.51	5.70	8.77	9.08	9.38	11.51	11.92	12.32	12.40	12.84	13.27	13.06	13.52	13.98
	SAT	40.1	39.7	39.4	40.8	40.4	40.1	40.3	39.9	39.6	38.6	38.1	37.7	37.8	37.3	36.8	37.2	36.7	36.2
	WF	309	320	331	466	483	499	768	795	822	1008	1043	1079	1086	1124	1162	1143	1183	1223
50-40	HC	2.22	2.35	2.48	3.48	3.67	3.86	5.82	6.12	6.42	7.63	8.02	8.42	8.21	8.63	9.06	8.64	9.08	9.53
	SAT	33.0	32.7	32.3	33.9	33.6	33.3	33.8	33.4	33.1	32.7	32.2	31.8	32.1	31.6	31.2	31.7	31.2	30.7
	WF	194	205	216	303	320	337	508	533	560	666	700	734	716	753	790	754	792	831

Legend:

HC Heating capacity (kW)
 SAT Supply air temperature (°C)
 WF Water flow rate (l/h)

NOTE:

- To convert l/h to l/s, divide by 3600.
- The supply air temperature should be kept below 35°C in order to avoid the risk of stratification.

7.9 - Sound power levels

7.9.1 - 42NL

42NL 2-5 (AC - multi-speed version)

		Octave band frequency (Hz)					
Speed	Type	125	250	500	1K	2K	dB(A)
R1	GLOBAL	52	57	56	53	48	57
R2	GLOBAL	49	54	54	49	44	54
R3	GLOBAL	47	51	51	46	41	51
R4	GLOBAL	44	47	48	42	37	48
R5	GLOBAL	42	42	42	34	27	41
R6	GLOBAL	40	39	39	31	24	38

42NL 3-5 (AC - multi-speed version)

		Octave band frequency (Hz)					
Speed	Type	125	250	500	1K	2K	dB(A)
R1	GLOBAL	57	61	60	57	52	61
R2	GLOBAL	56	60	58	55	50	59
R3	GLOBAL	53	57	56	52	47	57
R4	GLOBAL	50	54	53	49	45	54
R5	GLOBAL	42	47	46	40	36	46
R6	GLOBAL	40	44	43	37	32	43

42NL 4-5 (AC - multi-speed version)

		Octave band frequency (Hz)					
Speed	Type	125	250	500	1K	2K	dB(A)
R1	GLOBAL	58	62	62	58	54	63
R2	GLOBAL	56	60	59	56	51	60
R3	GLOBAL	53	57	57	53	49	58
R4	GLOBAL	50	54	54	49	45	55
R5	GLOBAL	42	48	48	41	37	48
R6	GLOBAL	40	46	44	38	32	44

42NL 5-5 (AC - multi-speed version)

		Octave band frequency (Hz)					
Speed	Type	125	250	500	1K	2K	dB(A)
R1	GLOBAL	60	63	61	57	52	62
R2	GLOBAL	57	61	58	54	49	59
R3	GLOBAL	55	57	56	51	47	57
R4	GLOBAL	53	54	52	48	43	53
R5	GLOBAL	47	47	45	39	35	46
R6	GLOBAL	45	44	42	36	30	42

7.9.2 - 42NH

42NH 2-5 (AC - multi-speed version)

		Octave band frequency (Hz)					
Speed	Type	125	250	500	1K	2K	dB(A)
R1	RET + RAD	52	50	48	40	34	48
	SUP	50	54	47	45	41	50
R2	RET + RAD	48	46	45	38	33	45
	SUP	46	51	45	41	38	47
R3	RET + RAD	43	45	44	35	33	44
	SUP	46	49	43	38	36	45
R4	RET + RAD	37	34	32	27	32	36
	SUP	38	42	37	30	30	38
R5	RET + RAD	35	31	25	25	30	33
	SUP	30	33	25	22	27	31

42NH 279 (EC - brushless motor)

		Octave band frequency (Hz)					
Speed	Type	125	250	500	1K	2K	dB(A)
10V	RET + RAD	62	63	61	54	47	61
	SUP	64	67	62	60	55	64
8V	RET + RAD	59	59	57	50	42	57
	SUP	61	63	58	56	51	61
6V	RET + RAD	55	54	53	45	36	52
	SUP	56	58	53	50	44	55
4V	RET + RAD	47	45	42	33	24	42
	SUP	47	48	44	36	32	44
2V	RET + RAD	38	34	31	21	15	32
	SUP	37	36	31	21	17	32

42NL 2-9 (EC - brushless motor)

		Octave band frequency (Hz)					
Speed	Type	125	250	500	1K	2K	dB(A)
10V	GLOBAL	45	48	49	43	36	48
8V	GLOBAL	43	44	45	38	30	44
6V	GLOBAL	42	40	39	31	22	39
4V	GLOBAL	52	33	29	20	11	37
2V	GLOBAL	46	30	22	17	10	31

42NL 3-9 (EC - brushless motor)

		Octave band frequency (Hz)					
Speed	Type	125	250	500	1K	2K	dB(A)
10V	GLOBAL	54	59	58	56	52	60
8V	GLOBAL	52	57	56	53	49	58
6V	GLOBAL	46	52	52	48	44	53
4V	GLOBAL	41	46	46	40	34	46
2V	GLOBAL	50	36	33	27	16	37

42NL 4-9 (EC - brushless motor)

		Octave band frequency (Hz)					
Speed	Type	125	250	500	1K	2K	dB(A)
10V	GLOBAL	61	66	63	64	59	67
8V	GLOBAL	59	64	61	61	57	65
6V	GLOBAL	54	59	57	55	52	60
4V	GLOBAL	47	51	51	47	45	52
2V	GLOBAL	40	40	36	33	24	38

42NL 5-9 (EC - brushless motor)

		Octave band frequency (Hz)					
Speed	Type	125	250	500	1K	2K	dB(A)
10V	GLOBAL	52	58	58	52	47	58
8V	GLOBAL	50	55	56	49	44	55
6V	GLOBAL	45	51	51	44	39	51
4V	GLOBAL	41	45	44	37	29	44
2V	GLOBAL	40	36	31	23	14	32

42NH 229 and 239 (EC - brushless motor)

		Octave band frequency (Hz)					
Speed	Type	125	250	500	1K	2K	dB(A)
10V	RET + RAD	57	58	55	49	41	56
	SUP	59	60	55	53	48	58
8V	RET + RAD	53	54	51	44	36	52
	SUP	55	56	51	48	43	53
6V	RET + RAD	49	51	48	40	31	47
	SUP	51	52	48	43	37	49
4V	RET + RAD	40	40	38	33	35	40
	SUP	41	45	38	31	32	41
2V	RET + RAD	36	36	34	29	31	36
	SUP	37	41	34	27	28	37

NOTE: All tables are based on Eurovent declaration conditions.

The measurements are based on ISO standards and are without supply and return octopus plenums.

The room sound level calculations must take account of the sound absorption of the duct, the plenum, the room and ceiling.

For a selected speed the sound level can vary within a tolerance of ± 2.5 dB(A), depending on the available static pressure.

7.9 - Sound power levels (continued)

42NH 3-5 (AC - multi-speed version)

Speed	Type	Octave band frequency (Hz)					dB(A)
		125	250	500	1K	2K	
R1	RET + RAD	57	61	59	54	50	60
	SUP	61	65	61	62	61	66
R2	RET + RAD	53	56	54	50	44	55
	SUP	56	59	55	57	54	60
R3	RET + RAD	51	51	48	45	38	49
	SUP	52	53	49	51	46	54
R4	RET + RAD	48	45	43	40	26	45
	SUP	50	48	45	44	38	48
R5	RET + RAD	42	39	35	31	40	42
	SUP	47	46	42	42	36	46

42NH 4-5 (AC - multi-speed version)

Speed	Type	Octave band frequency (Hz)					dB(A)
		125	250	500	1K	2K	
R1	RET + RAD	61	60	58	52	46	59
	SUP	60	62	59	56	51	61
R2	RET + RAD	60	59	57	51	45	58
	SUP	59	61	59	55	50	60
R3	RET + RAD	58	57	55	49	42	55
	SUP	57	59	57	53	48	58
R4	RET + RAD	53	52	52	44	37	51
	SUP	52	55	53	48	43	54
R5	RET + RAD	45	44	45	32	26	44
	SUP	46	48	47	39	33	47

42NH 5-5 (AC - multi-speed version)

Speed	Type	Octave band frequency (Hz)					dB(A)
		125	250	500	1K	2K	
R1	RET + RAD	58	61	57	52	47	58
	SUP	62	61	59	57	53	61
R2	RET + RAD	57	60	57	51	46	58
	SUP	61	61	59	56	52	60
R3	RET + RAD	56	59	56	50	45	57
	SUP	60	59	57	54	50	59
R4	RET + RAD	55	57	55	49	43	55
	SUP	59	58	56	52	48	57
R5	RET + RAD	52	55	54	46	40	53
	SUP	55	55	53	49	45	55

42NH 6-5 (AC - multi-speed version)

Speed	Type	Octave band frequency (Hz)					dB(A)
		125	250	500	1K	2K	
R1	RET + RAD	66	64	60	55	49	62
	SUP	67	67	62	61	55	66
R2	RET + RAD	65	63	59	54	48	61
	SUP	65	66	60	59	53	65
R3	RET + RAD	63	60	57	52	46	58
	SUP	63	64	58	57	51	62
R4	RET + RAD	60	57	56	48	42	56
	SUP	60	61	56	54	47	59
R5	RET + RAD	52	50	53	40	33	50
	SUP	53	53	52	45	39	50

42NH 7-5 (AC - multi-speed version)

Speed	Type	Octave band frequency (Hz)					dB(A)
		125	250	500	1K	2K	
R1	RET + RAD	66	66	62	58	52	64
	SUP	69	70	65	65	59	68
R2	RET + RAD	63	63	59	55	49	63
	SUP	66	67	62	61	55	66
R3	RET + RAD	58	58	58	49	43	57
	SUP	58	58	55	52	47	58
R4	RET + RAD	50	48	48	35	28	48
	SUP	53	49	47	38	33	48
R5	RET + RAD	37	40	43	24	16	41
	SUP	51	43	44	30	26	42

42NH 3-9 (EC - brushless motor)

Speed	Type	Octave band frequency (Hz)					dB(A)
		125	250	500	1K	2K	
10V	RET + RAD	64	66	64	59	57	65
	SUP	66	70	65	64	65	70
8V	RET + RAD	64	66	64	59	57	65
	SUP	65	69	65	63	65	70
6V	RET + RAD	61	63	60	56	52	61
	SUP	61	65	60	60	60	65
4V	RET + RAD	54	56	54	50	43	55
	SUP	56	57	54	54	49	57
2V	RET + RAD	42	43	44	36	27	43
	SUP	46	46	43	38	34	44

42NH 4-9 (EC - brushless motor)

Speed	Type	Octave band frequency (Hz)					dB(A)
		125	250	500	1K	2K	
10V	RET + RAD	67	68	62	60	57	65
	SUP	68	71	66	66	65	71
8V	RET + RAD	66	67	61	59	56	64
	SUP	67	70	66	65	65	70
6V	RET + RAD	60	62	56	55	52	60
	SUP	62	65	61	62	61	66
4V	RET + RAD	57	57	52	51	46	55
	SUP	57	59	55	57	55	61
2V	RET + RAD	42	43	44	36	27	43
	SUP	46	46	43	38	34	44

42NH 5-9 (EC - brushless motor)

Speed	Type	Octave band frequency (Hz)					dB(A)
		125	250	500	1K	2K	
10V	RET + RAD	69	70	65	59	55	67
	SUP	68	71	67	66	62	70
8V	RET + RAD	66	67	62	55	51	63
	SUP	65	67	63	61	58	66
6V	RET + RAD	60	61	57	50	46	58
	SUP	60	62	59	56	53	61
4V	RET + RAD	51	53	49	40	36	49
	SUP	51	53	52	46	43	53
2V	RET + RAD	39	42	32	21	19	35
	SUP	45	39	35	25	23	36

42NH 6-9 (EC - brushless motor)

Speed	Type	Octave band frequency (Hz)					dB(A)
		125	250	500	1K	2K	
10V	RET + RAD	73	73	68	63	61	70
	SUP	66	68	64	63	60	68
8V	RET + RAD	71	70	65	60	58	67
	SUP	64	65	60	59	56	64
6V	RET + RAD	65	65	60	54	53	62
	SUP	58	60	55	54	50	58
4V	RET + RAD	55	54	50	41	39	51
	SUP	50	52	49	44	41	50
2V	RET + RAD	42	45	35	24	22	39
	SUP	45	47	44	39	36	45

42NH 7-9 (EC - brushless motor)

Speed	Type	Octave band frequency (Hz)					dB(A)
		125	250	500	1K	2K	
10V	RET + RAD	66	66	63	56	53	64
	SUP	67	68	63	62	56	66
8V	RET + RAD	64	64	62	55	51	62
	SUP	65	66	61	58	54	63
6V	RET + RAD	59	59	58	50	50	58
	SUP	61	61	56	53	49	58
4V	RET + RAD	50	51	52	41	40	51
	SUP	52	52	49	43	41	50
2V	RET + RAD	45	46	47	36	35	46
	SUP	47	47	44	38	36	45

Legend:

SUP Supply (dB re = 10⁻¹² W)
RET Return (dB re = 10⁻¹² W)
RAD Radiated (dB re = 10⁻¹² W)
GLOBAL = SUP + RET + RAD
R Fixed speed

Air plenum attenuation:

The sound power level measurements were carried out on a non-ducted unit without return or supply air plenums.

If the unit includes a plenum, correct the sound power levels (RET or SUP) using the correction factors in the tables below:

Return plenum attenuation						
Unit Size 42NH/42NL	Octave band frequency (Hz)					
	125	250	500	1K	2K	dB(A)
2	-3.8	-6.8	-9.0	-8.9	-10.3	-6.7
3	-3.3	-7.8	-8.6	-9.5	-10.2	-7.0
4	-1.9	-5.2	-8.0	-6.6	-7.1	-4.9
5	-2.4	-6.1	-7.3	-5.5	-5.7	-5.1
6	-6.1	-10.0	-10.2	-10.5	-12.9	-9.0
7	-2.2	-5.8	-7.1	-6.9	-7.4	-5.3

Supply plenum attenuation						
Unit Size 42NH/42NL	Octave band frequency (Hz)					
	125	250	500	1K	2K	dB(A)
2	-1.2	-8.2	-9.8	-7.6	-8.4	-6.8
3	-1.3	-8.2	-8.8	-11.2	-10.2	-8.2
4	-1.0	-5.7	-8.3	-7.6	-8.6	-6.3
5	-2.6	-6.2	-9.1	-8.2	-9.4	-6.3
6	-1.9	-6.9	-9.1	-9.2	-10.1	-7.4
7	-2.2	-5.9	-6.6	-5.3	-5.7	-4.6

7.10 - Electrical data

7.10.1 - 42NL

42NL 2-5 (AC multi-speed version)

Speed	I	P	Qv	Qv	ESP	
	(A)	(W)	(l/s)	(m³/h)	G1 Filter (Pa)	
R1	0.35	80	138	495	0	
	0.35	80	136	490	3	
	0.35	79	131	470	12	
	0.35	79	125	450	19	
	0.35	78	119	430	26	
	0.35	77	114	410	33	
	0.34	77	108	390	38	
	0.34	76	103	370	44	
	0.34	76	97	350	48	
	0.34	75	92	330	53	
	0.34	75	86	310	57	
	0.34	75	81	290	60	
	0.33	73	56	200	73	
	R2	0.28	65	125	450	0
0.28		65	119	430	7	
0.28		64	114	410	14	
0.28		64	108	390	21	
0.27		63	103	370	27	
0.27		63	97	350	33	
0.27		62	92	330	38	
0.27		62	86	310	43	
0.27		61	81	290	48	
0.26		61	75	270	52	
0.26		60	69	250	56	
0.26		59	64	230	60	
0.26		59	58	210	63	
0.26		58	53	190	67	
0.26		58	47	170	70	
R3		0.23	54	110	394	0
		0.23	53	103	370	10
		0.23	53	97	350	18
	0.23	52	92	330	25	
	0.23	51	86	310	30	
	0.23	51	81	290	35	
	0.23	50	75	270	40	
	0.22	50	69	250	44	
	0.22	49	64	230	49	
	0.22	49	58	210	53	
	0.21	48	53	190	57	
	0.21	48	47	170	62	
	0.21	48	42	150	68	
	R4	0.20	45	96	345	0
		0.20	45	94	340	2
		0.20	45	89	320	9
0.20		44	83	300	15	
0.19		44	78	280	21	
0.19		43	72	260	27	
0.19		43	67	240	32	
0.19		42	61	220	38	
0.18		42	56	200	43	
0.18		41	50	180	49	
0.18		41	44	160	55	
R5		0.14	31	69	247	0
		0.14	31	68	245	1
		0.14	31	65	235	4
	0.13	31	56	200	13	
	0.13	31	50	180	18	
	0.13	31	47	170	21	
	0.13	31	44	160	24	
	0.13	30	42	150	27	
	0.13	30	39	140	30	
	0.13	30	36	130	33	
	0.13	29	33	120	36	
	0.13	29	31	110	39	
	R6	0.12	28	61	211	0
		0.12	27	50	180	6
0.12		27	47	170	8	
0.12		27	44	160	11	
0.12		27	42	150	13	
0.12		27	39	140	15	
0.12		27	36	130	18	
0.12		27	28	100	26	

42NL 2-9 (EC brushless motor)

Speed	I	P	Qv	Qv	ESP	
	(A)	(W)	(l/s)	(m³/h)	G1 Filter (Pa)	
10V	0.14	13	103	370	0	
	0.13	13	97	350	4	
	0.13	13	90	325	9	
	0.13	13	94	340	6	
	0.13	13	89	320	10	
	0.13	12	83	300	14	
	0.12	12	78	280	18	
	0.11	10	56	200	30	
	0.09	8	28	100	42	
	9V	0.12	12	97	350	0
0.12		12	90	325	5	
0.12		11	83	300	10	
0.12		11	76	275	15	
0.12		10	69	250	19	
0.11		10	63	225	23	
0.10		9	56	200	26	
8V	0.10	9	49	175	29	
	0.09	8	28	100	37	
	0.11	10	89	320	0	
	0.11	10	83	300	4	
	0.11	9	75	270	10	
	0.10	9	67	240	14	
	0.10	8	58	210	19	
	0.09	8	50	180	22	
	0.09	7	42	150	26	
	0.09	7	33	120	30	
7V	0.08	7	25	90	33	
	0.10	9	81	292	0	
	0.10	8	76	275	3	
	0.09	8	69	250	8	
	0.09	8	64	230	11	
	0.09	7	58	210	14	
	0.08	7	42	150	21	
	0.08	6	28	100	26	
6V	0.07	6	21	75	28	
	0.08	7	74	261	0	
	0.07	7	69	250	2	
	0.07	6	64	230	4	
	0.07	6	58	210	7	
	0.07	6	53	190	10	
	0.07	6	47	170	13	
	0.07	5	42	150	15	
	0.07	5	31	110	20	
	0.07	5	21	75	23	
5V	0.06	5	65	235	0	
	0.06	5	60	215	2	
	0.06	5	56	200	4	
	0.06	5	50	180	7	
	0.06	5	44	160	9	
	0.06	5	39	140	11	
	0.06	4	33	120	13	
	0.06	4	28	100	15	
	0.05	4	17	60	18	
	4V	0.06	5	58	210	0
0.06		4	56	200	1	
0.06		4	49	175	4	
0.06		4	42	150	7	
0.06		4	35	125	10	
0.06		4	28	100	12	
0.06		4	21	75	14	
0.05		3	14	50	16	
3V		0.06	4	51	182	0
		0.06	3	47	170	1
	0.06	3	42	150	3	
	0.05	3	28	100	8	
	0.05	3	14	50	11	
2V	0.05	3	43	155	0	
	0.05	3	38	135	2	
	0.05	3	32	115	3	
	0.05	3	26	95	5	
	0.04	2	11	40	8	

Legend

- I** Current drawn by the fan motor
- P** Power input to the fan motor
- Qv** Air flow rate
- ESP** Available external static pressure
- R** Fixed speed

7.10.1 - 42NL (continued)

42NL 3-5 (AC multi-speed version)

Speed	I	P	Qv	Qv	ESP	
						(A)
R1	0.44	99	168	605	0	
	0.44	99	167	600	3	
	0.43	98	161	580	11	
	0.43	96	156	560	18	
	0.42	95	150	540	25	
	0.41	94	144	520	31	
	0.41	93	139	500	37	
	0.41	92	133	480	43	
	0.40	91	128	460	48	
	0.40	90	122	440	53	
	0.39	90	117	420	58	
	0.39	89	111	400	62	
	0.39	89	106	380	66	
	0.39	88	100	360	70	
	R2	0.37	86	154	555	0
0.37		85	153	550	2	
0.36		84	147	530	11	
0.35		82	142	510	20	
0.35		81	136	490	27	
0.34		80	131	470	34	
0.34		79	125	450	40	
0.34		78	119	430	46	
0.33		77	114	410	51	
0.33		77	108	390	56	
0.33		76	103	370	61	
0.32		75	97	350	65	
0.32		75	92	330	69	
0.32		75	90	325	70	
R3		0.32	74	143	515	0
	0.31	73	139	500	8	
	0.31	72	133	480	16	
	0.30	71	128	460	24	
	0.30	70	122	440	31	
	0.29	69	117	420	37	
	0.29	68	111	400	43	
	0.29	67	106	380	48	
	0.28	66	100	360	53	
	0.28	65	94	340	57	
	0.28	64	89	320	62	
	0.27	64	83	300	66	
	0.27	63	78	280	69	
	R4	0.27	62	124	445	0
		0.27	62	122	440	4
0.26		60	117	420	13	
0.26		59	111	400	22	
0.25		57	106	380	30	
0.25		57	100	360	37	
0.24		56	94	340	43	
0.24		55	89	320	48	
0.24		55	83	300	54	
0.24		54	78	280	58	
0.24		54	72	260	63	
0.23		54	67	240	67	
R5		0.20	45	94	340	0
		0.19	44	89	320	7
		0.19	43	83	300	15
	0.18	42	78	280	22	
	0.18	42	72	260	29	
	0.18	41	67	240	36	
	0.18	41	61	220	42	
	0.18	41	56	200	48	
R6	0.16	38	83	300	0	
	0.16	37	78	280	7	
	0.16	37	72	260	14	
	0.16	37	67	240	20	
	0.16	37	61	220	26	
	0.16	36	56	200	32	
	0.16	36	50	180	38	
	0.16	36	44	160	44	

42NL 3-9 (EC brushless motor)

Speed	I	P	Qv	Qv	ESP
10V	0.39	49	168	605	0
	0.39	49	167	600	2
	0.38	48	161	580	8
	0.37	47	156	560	14
	0.37	46	150	540	20
	0.36	45	144	520	27
	0.35	44	139	500	33
	0.34	43	133	480	39
	0.31	39	111	400	64
	9V	0.35	41	153	550
0.34		40	147	530	9
0.33		39	142	510	17
0.31		38	136	490	24
0.30		37	131	470	31
0.30		37	125	450	37
0.29		36	119	430	43
0.28		35	114	410	49
0.27		33	103	370	59
8V		0.30	34	144	517
	0.30	34	142	510	3
	0.28	33	136	490	11
	0.27	32	131	470	19
	0.26	31	125	450	25
	0.25	31	119	430	31
	0.24	30	114	410	37
	0.23	27	97	350	51
	0.22	26	89	320	56
	7V	0.27	33	133	480
0.26		32	128	460	6
0.25		31	122	440	13
0.24		30	117	420	19
0.24		29	111	400	24
0.23		29	106	380	29
0.23		28	100	360	33
0.22		25	83	300	44
0.20		23	69	250	53
6V		0.17	20	119	430
	0.16	19	111	400	8
	0.16	18	106	380	13
	0.16	18	100	360	17
	0.15	17	94	340	21
	0.15	16	83	300	28
	0.14	15	69	250	37
	0.13	14	56	200	46
	0.12	14	53	190	48
	5V	0.14	15	103	370
0.13		14	97	350	5
0.13		14	92	330	10
0.13		13	86	310	14
0.12		13	81	290	18
0.12		12	75	270	22
0.12		12	69	250	25
0.11		11	56	200	33
0.09		10	42	150	42
4V		0.10	10	89	320
	0.10	9	83	300	4
	0.10	9	78	280	9
	0.09	9	72	260	12
	0.09	8	67	240	15
	0.09	8	61	220	18
	0.09	8	56	200	21
	0.09	7	42	150	26
	0.08	7	28	100	32
	3V	0.08	7	69	250
0.08		6	56	200	10
0.07		6	42	150	16
0.07		5	28	100	21
0.05		4	14	50	26
2V		0.06	4	54	195
	0.06	4	42	150	6
	0.06	4	28	100	10
	0.05	3	14	50	13
	0.05	3	7	25	15

Legend

- I** Current drawn by the fan motor
- P** Power input to the fan motor
- Qv** Air flow rate
- ESP** Available external static pressure
- R** Fixed speed

7.10.1 - 42NL (continued)

42NL 4-5 (AC multi-speed version)

Speed	I	P	Qv	Qv	ESP
	(A)	(W)	(l/s)	(m³/h)	G1 Filter (Pa)
R1	0.69	157	299	1075	0
	0.69	156	292	1050	6
	0.68	155	278	1000	17
	0.68	154	264	950	26
	0.67	152	250	900	35
	0.67	150	236	850	42
	0.66	149	222	800	50
	0.65	147	208	750	56
	0.65	145	194	700	62
	0.64	144	181	650	68
	0.63	142	167	600	73
	0.63	141	153	550	78
	R2	0.57	129	267	960
0.57		129	264	950	3
0.56		128	257	925	10
0.56		127	250	900	16
0.55		126	242	870	23
0.55		125	233	840	29
0.54		123	225	810	35
0.54		122	217	780	40
0.53		121	208	750	45
0.52		118	181	650	59
0.51		116	167	600	65
0.50		114	153	550	70
R3		0.49	113	233	840
	0.49	111	228	820	7
	0.48	110	222	800	14
	0.48	109	217	780	20
	0.47	107	211	760	26
	0.47	106	206	740	31
	0.46	105	200	720	35
	0.46	104	194	700	39
	0.46	103	189	680	43
	0.45	103	183	660	46
	0.45	102	178	640	49
	0.44	99	153	550	60
	R4	0.43	98	208	750
0.42		96	201	725	9
0.41		94	194	700	17
0.40		92	188	675	24
0.40		91	181	650	30
0.39		89	174	625	35
0.39		89	167	600	40
0.38		88	160	575	44
0.38		87	153	550	48
0.38		87	146	525	51
0.38		86	139	500	55
0.37		86	132	475	58
R5		0.30	68	149	535
	0.30	68	147	530	3
	0.29	66	139	500	14
	0.29	65	133	480	20
	0.28	65	128	460	24
	0.28	64	122	440	28
	0.28	64	119	430	30
	0.28	64	117	420	31
	0.28	64	114	410	33
	0.28	64	111	400	35
	0.28	64	108	390	36
	0.28	63	106	380	37
	R6	0.25	57	129	465
0.25		57	125	450	5
0.25		56	119	430	11
0.25		56	114	410	17
0.24		56	108	390	21
0.24		55	103	370	25
0.24		55	97	350	28
0.24		55	92	330	31
0.24		55	86	310	33

42NL 4-9 (EC brushless motor)

Speed	I	P	Qv	Qv	ESP	
	(A)	(W)	(l/s)	(m³/h)	G1 Filter (Pa)	
10V	0.80	99	226	815	0	
	0.79	99	222	800	7	
	0.79	99	215	775	19	
	0.79	99	208	750	31	
	0.78	98	201	725	43	
	0.77	97	194	700	54	
	0.76	95	188	675	64	
	0.74	93	181	650	74	
	0.73	91	174	625	83	
	9V	0.75	91	217	780	0
0.72		89	208	750	14	
0.70		87	201	725	26	
0.69		85	194	700	36	
0.67		83	188	675	46	
0.66		81	181	650	56	
0.64		79	174	625	65	
0.63		77	167	600	73	
0.61		75	160	575	81	
8V		0.65	78	207	745	0
	0.63	76	201	725	8	
	0.60	73	194	700	19	
	0.58	71	188	675	29	
	0.57	70	181	650	38	
	0.56	68	174	625	46	
	0.55	66	167	600	53	
	0.54	65	160	575	60	
	0.53	64	153	550	67	
	7V	0.54	58	192	690	0
0.53		58	188	675	5	
0.50		57	181	650	13	
0.48		55	174	625	21	
0.46		54	167	600	28	
0.44		53	160	575	35	
0.43		52	153	550	42	
0.42		51	146	525	49	
0.41		49	139	500	55	
6V		0.38	42	169	610	0
	0.37	42	167	600	3	
	0.35	41	160	575	10	
	0.33	40	153	550	17	
	0.32	39	146	525	24	
	0.31	38	139	500	31	
	0.30	36	132	475	37	
	0.30	35	125	450	44	
	0.29	34	118	425	49	
	5V	0.29	30	150	540	0
0.28		29	146	525	3	
0.27		28	139	500	9	
0.25		28	132	475	15	
0.24		27	125	450	21	
0.23		26	118	425	27	
0.22		25	111	400	32	
0.22		24	104	375	37	
0.21		23	97	350	41	
4V		0.18	18	124	445	0
	0.17	18	118	425	4	
	0.16	17	111	400	8	
	0.15	17	104	375	13	
	0.14	16	97	350	17	
	0.14	15	90	325	21	
	0.13	15	83	300	25	
	0.13	14	76	275	28	
	0.13	13	69	250	32	
	3V	0.12	11	97	350	0
0.11		10	83	300	8	
0.10		9	69	250	15	
0.10		9	56	200	21	
0.09		8	42	150	26	
2V		0.07	6	67	240	0
		0.07	5	56	200	4
		0.07	5	42	150	9
		0.06	4	28	100	12
		0.06	4	14	50	15

Legend

- I Current drawn by the fan motor
- P Power input to the fan motor
- Qv Air flow rate
- ESP Available external static pressure
- R Fixed speed

7.10.1 - 42NL (continued)

42NL 5-5 (AC multi-speed version)

Speed	I	P	Qv	Qv	ESP
	(A)	(W)	(l/s)	(m ³ /h)	G1 Filter (Pa)
R1	0.74	170	358	1290	0
	0.74	169	354	1275	2
	0.73	168	347	1250	6
	0.73	167	340	1225	10
	0.73	166	333	1200	14
	0.72	164	319	1150	21
	0.71	162	306	1100	28
	0.70	160	292	1050	35
	0.69	158	278	1000	41
	0.69	156	264	950	48
	0.68	155	250	900	54
	0.66	150	208	750	71
R2	0.60	137	313	1125	0
	0.60	136	306	1100	5
	0.59	135	299	1075	9
	0.59	134	292	1050	13
	0.58	132	278	1000	21
	0.57	129	264	950	29
	0.56	128	250	900	37
	0.55	126	236	850	44
	0.54	124	222	800	51
	0.54	122	208	750	58
	0.53	121	194	700	64
	0.52	119	181	650	70
R3	0.52	118	275	990	0
	0.51	116	264	950	8
	0.50	115	257	925	13
	0.50	113	250	900	18
	0.49	112	243	875	23
	0.49	111	236	850	28
	0.48	110	229	825	32
	0.48	109	222	800	37
	0.47	108	215	775	41
	0.47	107	208	750	45
	0.46	106	194	700	53
	0.45	103	167	600	66
R4	0.43	99	233	840	0
	0.43	97	222	800	10
	0.42	95	215	775	15
	0.42	94	208	750	21
	0.41	94	201	725	26
	0.41	93	194	700	31
	0.40	92	188	675	35
	0.40	91	181	650	39
	0.40	90	174	625	43
	0.40	90	167	600	47
	0.39	89	160	575	51
	0.39	89	153	550	54
R5	0.30	67	169	610	0
	0.30	67	167	600	2
	0.30	67	160	575	8
	0.29	66	153	550	13
	0.29	66	146	525	17
	0.29	66	139	500	22
	0.29	65	132	475	26
	0.29	65	125	450	30
	0.28	64	118	425	34
	0.28	64	111	400	37
	0.28	64	104	375	41
	0.28	63	97	350	45
R6	0.26	58	149	535	0
	0.25	58	139	500	8
	0.25	57	132	475	12
	0.25	57	125	450	16
	0.25	57	118	425	20
	0.25	57	111	400	24
	0.25	56	104	375	27
	0.25	56	97	350	31
	0.25	56	90	325	35

42NL 5-9 (EC brushless motor)

Speed	I	P	Qv	Qv	ESP	
	(A)	(W)	(l/s)	(m ³ /h)	G1 Filter (Pa)	
10V	0.39	58	254	915	0	
	0.39	57	250	900	3	
	0.37	55	236	850	11	
	0.36	54	222	800	18	
	0.35	52	208	750	26	
	0.34	50	194	700	33	
	0.33	49	181	650	41	
	0.32	47	167	600	48	
	0.29	44	139	500	62	
	9V	0.34	51	243	875	0
		0.34	50	236	850	4
		0.32	48	222	800	11
0.31		46	208	750	18	
0.30		44	194	700	25	
0.28		42	181	650	32	
8V	0.27	41	167	600	38	
	0.26	39	153	550	45	
	0.24	36	125	450	58	
	0.28	43	229	825	0	
	0.28	42	222	800	4	
	0.26	39	208	750	10	
7V	0.25	37	194	700	16	
	0.24	36	181	650	23	
	0.23	34	167	600	29	
	0.22	33	153	550	35	
	0.22	32	139	500	42	
	0.20	30	111	400	54	
	6V	0.22	33	208	750	0
		0.21	31	194	700	6
		0.20	29	181	650	13
		0.19	28	167	600	19
		0.19	27	153	550	25
		0.18	26	139	500	31
0.17		25	125	450	36	
0.17		24	111	400	42	
0.15		22	83	300	52	
5V		0.17	24	186	670	0
		0.16	23	181	650	3
		0.16	22	167	600	9
	0.15	21	153	550	14	
	0.14	20	139	500	20	
	0.14	19	125	450	24	
	0.13	18	111	400	29	
	0.13	17	97	350	34	
	0.11	15	69	250	42	
	4V	0.13	18	169	610	0
		0.13	17	167	600	1
		0.12	16	153	550	5
0.12		16	139	500	10	
0.11		15	125	450	14	
0.11		14	111	400	19	
0.10		13	97	350	23	
0.10		13	83	300	27	
0.09		11	56	200	35	
3V		0.09	11	139	500	0
		0.08	10	125	450	4
		0.08	10	111	400	8
	0.08	9	97	350	12	
	0.07	9	83	300	16	
	0.07	8	69	250	20	
	0.07	8	56	200	23	
	0.06	7	42	150	26	
	0.06	7	28	100	29	
	2V	0.06	7	111	400	0
		0.06	7	97	350	4
		0.06	6	83	300	8
0.06		6	69	250	11	
0.05		5	28	100	19	
1V		0.04	4	83	295	0
	0.04	4	69	250	2	
	0.04	4	56	200	5	
	0.04	3	42	150	7	
	0.04	3	28	100	9	

Legend

- I** Current drawn by the fan motor
- P** Power input to the fan motor
- Qv** Air flow rate
- ESP** Available external static pressure
- R** Fixed speed

7.10.2 - 42NH (continued)

42NH 3-5 (AC multi-speed version)

Speed	I	P	Qv	Qv	ESP		
					G1 Filter (Pa)	G3 Filter (Pa)	
(A)	(W)	(l/s)	(m³/h)				
R1	0.88	201	199	716	0	-	
	0.88	201	194	700	12	-	
	0.88	200	192	690	20	2	
	0.88	200	189	680	28	11	
	0.87	199	186	670	37	20	
	0.87	198	183	660	46	29	
	0.87	197	181	650	56	39	
	0.85	195	174	625	80	64	
	0.84	192	167	600	105	90	
	0.82	190	160	575	129	114	
	0.81	186	153	550	151	137	
	0.79	183	146	525	170	158	
	0.77	179	139	500	186	174	
	0.76	175	132	475	198	187	
	R2	0.75	173	159	572	0	-
0.75		173	158	570	2	-	
0.75		173	153	550	16	3	
0.75		172	147	530	32	19	
0.75		171	142	510	49	37	
0.74		170	136	490	66	55	
0.73		168	131	470	84	73	
0.72		166	125	450	101	91	
0.71		164	119	430	118	108	
0.70		161	114	410	133	124	
0.69		158	108	390	146	137	
0.68		155	103	370	157	149	
0.67		152	97	350	166	158	
0.64		145	86	310	172	165	
R3		0.65	150	124	448	0	-
	0.65	150	124	445	2	-	
	0.65	148	111	400	30	21	
	0.64	147	106	380	41	33	
	0.64	146	100	360	52	44	
	0.63	144	94	340	64	56	
	0.63	143	89	320	77	70	
	0.62	141	83	300	91	84	
	0.62	140	81	290	99	93	
	0.61	139	78	280	108	102	
	0.61	138	75	270	115	111	
	0.61	137	72	260	121	115	
	R4	0.57	129	94	340	0	-
		0.57	128	88	315	16	9
		0.57	127	83	300	23	17
0.56		127	81	290	27	21	
0.56		126	78	280	31	25	
0.56		125	75	270	35	29	
0.56		125	72	260	38	33	
0.56		124	69	250	43	37	
0.55		124	67	240	47	41	
0.55		124	64	230	51	45	
0.55		123	61	220	55	51	
0.55		123	58	210	61	56	
0.55		124	50	180	75	72	
R5		0.50	111	65	233	0	-
		0.49	110	63	225	4	-
	0.49	109	56	200	15	10	
	0.49	109	53	190	18	14	
	0.49	109	50	180	21	17	
	0.49	108	47	170	24	20	
	0.49	108	44	160	27	24	
	0.48	107	39	140	34	32	
	0.48	107	33	120	42	40	
	0.48	107	28	100	50	48	

42NH 3-9 (EC brushless motor)

Speed	I	P	Qv	Qv	ESP	
					G1 Filter (Pa)	G3 Filter (Pa)
(A)	(W)	(l/s)	(m³/h)			
10V	1.35	176	278	1000	0	-
	1.34	175	264	950	22	-
	1.34	174	250	900	44	19
	1.33	173	236	850	67	43
	1.33	172	222	800	89	67
	1.33	172	208	750	111	91
	1.33	172	194	700	134	115
	1.32	172	181	650	156	140
	1.32	172	153	550	202	188
	9V	1.27	173	278	1000	0
1.27		173	264	950	20	-
1.27		173	250	900	41	15
1.27		173	236	850	61	38
1.27		172	222	800	81	60
1.26		171	208	750	101	81
1.25		170	194	700	121	103
1.22		164	167	600	160	133
1.19		161	153	550	179	162
8V		1.27	173	278	1000	0
	1.27	173	264	950	18	-
	1.27	173	250	900	37	11
	1.27	173	236	850	56	32
	1.27	172	222	800	74	52
	1.26	171	208	750	91	71
	1.25	170	194	700	108	90
	1.22	164	167	600	140	125
	1.15	156	139	500	171	159
	7V	1.14	154	274	988	0
1.14		154	271	975	4	-
1.13		153	264	950	12	-
1.11		151	250	900	27	1
1.07		144	222	800	54	32
1.01		136	194	700	79	61
0.95		127	167	600	103	88
0.90		120	139	500	127	115
0.85		114	111	400	153	144
6V		0.79	103	250	900	0
	0.78	102	236	850	12	-
	0.77	100	222	800	24	2
	0.75	99	208	750	35	15
	0.74	97	194	700	47	28
	0.70	92	167	600	69	54
	0.66	86	139	500	89	77
	0.61	80	111	400	108	98
	0.56	72	83	300	124	117
	5V	0.57	73	229	825	0
0.57		73	222	800	5	-
0.56		72	194	700	24	6
0.53		69	167	600	43	28
0.50		64	139	500	61	49
0.46		59	111	400	76	67
0.38		48	69	250	95	88
0.36		46	63	225	98	91
0.34		43	56	200	101	93
4V		0.37	47	200	720	0
	0.37	47	194	700	3	-
	0.35	44	167	600	18	3
	0.33	42	139	500	32	21
	0.31	38	111	400	46	37
	0.28	35	83	300	59	52
	0.25	31	56	200	73	69
	0.24	29	42	150	78	74
	0.23	29	36	130	80	76
	3V	0.24	28	160	575	0
0.23		27	153	550	3	-
0.22		26	139	500	9	-
0.17		20	69	250	36	31
0.14		16	28	100	49	47
2V	0.11	12	122	440	0	-
	0.11	12	111	400	5	-
	0.10	11	83	300	13	6
	0.09	10	56	200	18	14
	0.08	8	28	100	23	21

Legend

- I** Current drawn by the fan motor
- P** Power input to the fan motor
- Qv** Air flow rate
- ESP** Available external static pressure
- R** Fixed speed

7.10.2 - 42NH (continued)

42NH 4-5 (AC multi-speed version)

Speed	I	P	Qv	Qv	ESP	
					G1 Filter (Pa)	G3 Filter (Pa)
	(A)	(W)	(l/s)	(m³/h)		
R1	0.72	161	369	1330	0	-
	0.71	158	361	1300	6	-
	0.67	150	333	1200	25	-
	0.63	142	306	1100	42	19
	0.60	134	278	1000	58	38
	0.58	128	250	900	73	55
	0.56	125	236	850	80	64
	0.55	122	222	800	87	72
	0.54	119	208	750	93	79
	0.53	117	194	700	99	87
	0.52	114	181	650	106	94
	0.50	112	167	600	111	101
	0.49	109	153	550	117	108
	0.47	105	125	450	128	121
	R2	0.67	148	325	1170	0
0.65		145	319	1150	5	-
0.60		134	292	1050	27	6
0.55		123	264	950	47	28
0.52		115	236	850	64	48
0.49		107	208	750	80	66
0.47		104	194	700	87	75
0.46		101	181	650	94	83
0.44		98	167	600	101	90
0.43		95	153	550	107	98
0.42		93	139	500	113	105
0.40		90	125	450	120	112
0.40		89	118	425	123	116
0.39		88	111	400	126	119
R3		0.62	133	246	885	0
	0.57	124	236	850	16	0
	0.54	119	229	825	26	11
	0.52	114	222	800	36	21
	0.50	110	215	775	44	29
	0.48	107	208	750	51	37
	0.46	101	194	700	63	50
	0.44	97	181	650	73	61
	0.43	94	167	600	80	70
	0.41	91	153	550	87	78
	0.40	88	139	500	95	86
	0.38	84	125	450	103	95
	0.37	82	118	425	107	100
	0.36	79	111	400	113	106
	R4	0.51	109	171	615	0
0.49		104	167	600	12	2
0.46		98	160	575	29	19
0.44		94	153	550	44	34
0.42		90	146	525	55	46
0.40		86	139	500	65	56
0.39		84	132	475	72	65
0.38		82	125	450	79	71
0.37		80	118	425	84	77
0.36		78	111	400	89	83
0.35		76	104	375	94	88
0.34		74	97	350	99	93
0.33		71	90	325	104	99
0.31		68	83	300	111	106
R5		0.43	87	115	415	0
	0.42	86	111	400	8	2
	0.41	85	108	390	15	8
	0.40	84	106	380	21	15
	0.39	82	103	370	28	22
	0.39	81	100	360	36	30
	0.38	79	97	350	43	37
	0.37	78	94	340	50	44
	0.36	76	92	330	57	51
	0.35	75	89	320	63	58
	0.35	73	86	310	69	64
	0.34	72	83	300	74	69
	0.33	71	81	290	78	73
	0.32	70	78	280	81	76

42NH 4-9 (EC brushless motor)

Speed	I	P	Qv	Qv	ESP	
					G1 Filter (Pa)	G3 Filter (Pa)
	(A)	(W)	(l/s)	(m³/h)		
10V	1.31	173	292	1050	0	-
	1.31	173	278	1000	31	10
	1.31	173	264	950	60	41
	1.31	173	250	900	87	70
	1.31	173	236	850	113	96
	1.30	172	222	800	137	122
	1.30	171	208	750	160	146
	1.30	171	194	700	182	170
	1.30	171	181	650	204	193
	9V	1.31	173	292	1050	0
1.31		173	278	1000	31	10
1.31		173	264	950	60	41
1.31		173	250	900	87	70
1.31		173	236	850	113	96
1.30		172	222	800	137	122
1.30		171	208	750	160	146
1.30		171	194	700	182	170
1.30		171	181	650	204	193
8V		1.31	173	292	1050	0
	1.31	173	278	1000	31	10
	1.31	173	264	950	60	41
	1.31	173	250	900	87	70
	1.31	173	236	850	113	96
	1.30	172	222	800	137	122
	1.30	171	208	750	160	146
	1.30	171	194	700	182	170
	1.30	171	181	650	204	193
	7V	1.26	166	276	992	0
1.24		164	271	975	13	-
1.22		161	264	950	31	12
1.12		148	236	850	85	69
1.02		135	208	750	119	105
0.93		123	181	650	138	127
0.86		113	153	550	153	144
0.82		109	139	500	161	153
0.79		105	125	450	171	163
6V		0.98	129	260	935	0
	0.93	123	250	900	20	2
	0.87	115	236	850	43	26
	0.82	108	222	800	62	47
	0.78	103	208	750	77	64
	0.75	98	194	700	91	78
	0.70	91	167	600	112	101
	0.64	83	139	500	130	121
	0.58	75	111	400	150	143
	5V	0.66	84	229	825	0
0.64		82	222	800	11	-
0.63		80	215	775	21	7
0.61		78	208	750	31	17
0.55		70	181	650	60	48
0.49		62	153	550	80	70
0.44		55	125	450	96	88
0.42		53	111	400	104	98
0.41		52	97	350	114	108
4V		0.43	53	190	685	0
	0.41	51	181	650	17	5
	0.38	48	167	600	35	24
	0.36	44	153	550	47	37
	0.33	41	139	500	55	47
	0.31	39	125	450	61	54
	0.30	37	111	400	66	60
	0.30	36	104	375	69	63
	0.29	36	97	350	72	67
	3V	0.24	29	149	535	0
0.22		26	139	500	13	4
0.19		22	111	400	30	24
0.18		22	83	300	42	37
0.18		22	76	275	44	40
2V		0.12	13	107	385	0
	0.11	12	97	350	8	2
	0.10	11	83	300	15	10
	0.10	10	69	250	19	15
	0.10	11	35	125	30	28

Legend

- I** Current drawn by the fan motor
- P** Power input to the fan motor
- Qv** Air flow rate
- ESP** Available external static pressure
- R** Fixed speed

7.10.2 - 42NH (continued)

42NH 5-5 (AC multi-speed version)

Speed	I	P	Qv	Qv	ESP	
					G1 Filter (Pa)	G3 Filter (Pa)
(A)	(W)	(l/s)	(m³/h)			
R1	0.76	168	403	1450	0	-
	0.74	163	389	1400	9	-
	0.70	154	361	1300	26	5
	0.67	147	333	1200	41	22
	0.64	140	306	1100	55	38
	0.61	134	278	1000	68	53
	0.59	128	250	900	80	67
	0.57	123	222	800	92	81
	0.54	118	194	700	105	95
	0.53	113	167	600	117	109
0.51	108	139	500	131	124	
0.50	105	125	450	138	132	
0.49	103	111	400	146	141	
R2	0.71	156	378	1360	0	-
	0.69	152	361	1300	11	-
	0.65	143	333	1200	28	9
	0.61	135	306	1100	43	26
	0.57	126	278	1000	57	42
	0.54	119	250	900	71	58
	0.51	112	222	800	85	73
	0.48	106	194	700	98	89
	0.48	103	167	600	112	104
	0.48	101	139	500	127	120
0.49	102	125	450	135	129	
0.50	103	111	400	143	138	
R3	0.67	147	343	1235	0	-
	0.65	143	333	1200	8	-
	0.63	137	319	1150	18	0
	0.60	132	306	1100	28	11
	0.58	128	292	1050	37	21
	0.56	123	278	1000	45	30
	0.54	119	264	950	53	39
	0.52	115	250	900	60	47
	0.51	111	236	850	67	55
	0.49	108	222	800	74	63
0.47	101	194	700	88	79	
0.44	95	167	600	103	95	
0.41	90	139	500	119	112	
0.39	85	111	400	137	132	
R4	0.64	137	299	1075	0	-
	0.63	134	292	1050	7	-
	0.59	127	278	1000	20	5
	0.56	122	264	950	32	18
	0.54	116	250	900	43	29
	0.51	111	236	850	52	40
	0.49	107	222	800	61	50
	0.47	103	208	750	70	59
	0.46	100	194	700	77	68
	0.45	97	181	650	85	76
0.43	92	153	550	98	90	
0.41	89	111	400	122	111	
R5	0.59	123	247	890	0	-
	0.55	116	236	850	15	3
	0.51	109	222	800	31	20
	0.48	104	208	750	45	34
	0.46	99	194	700	56	47
	0.44	95	181	650	66	57
	0.42	92	167	600	75	67
	0.41	89	153	550	83	76
	0.39	86	139	500	91	85
	0.38	84	132	475	95	89
0.37	82	125	450	99	94	
0.35	77	111	400	108	103	

42NH 5-9 (EC brushless motor)

Speed	I	P	Qv	Qv	ESP	
					G1 Filter (Pa)	G3 Filter (Pa)
(A)	(W)	(l/s)	(m³/h)			
10V	1.88	252	513	1845	0	-
	1.88	252	500	1800	17	-
	1.88	252	472	1700	51	20
	1.88	249	444	1600	77	49
	1.87	242	417	1500	98	72
	1.80	232	389	1400	114	90
	1.72	219	361	1300	127	106
	1.52	190	306	1100	151	134
	1.31	159	250	900	181	168
	9V	1.85	236	506	1820	0
1.84		235	500	1800	5	-
1.79		228	472	1700	30	0
1.73		221	444	1600	53	25
1.68		213	417	1500	74	48
1.62		205	389	1400	92	69
1.49		187	333	1200	125	106
1.35		167	278	1000	152	137
1.21		147	222	800	176	165
8V		1.58	198	481	1730	0
	1.56	195	472	1700	6	-
	1.49	187	444	1600	24	-
	1.43	178	417	1500	42	16
	1.31	162	361	1300	75	54
	1.20	146	306	1100	105	88
	1.08	130	250	900	132	119
	0.97	115	194	700	154	145
	0.85	100	139	500	172	166
	7V	1.27	156	431	1550	0
1.22		150	417	1500	9	-
1.15		139	389	1400	26	3
1.08		130	361	1300	43	22
1.03		123	333	1200	58	39
0.98		116	306	1100	72	55
0.93		110	278	1000	86	71
0.84		98	222	800	108	97
0.65		73	139	500	134	128
6V		0.95	112	383	1380	0
	0.92	108	375	1350	5	-
	0.89	103	361	1300	12	-
	0.77	89	306	1100	39	23
	0.73	83	278	1000	52	37
	0.69	79	250	900	63	50
	0.66	74	222	800	74	63
	0.62	70	194	700	84	74
	0.45	49	111	400	108	103
	5V	0.67	76	333	1200	0
0.64		72	319	1150	6	-
0.61		68	306	1100	12	-
0.58		65	292	1050	18	2
0.56		62	278	1000	24	9
0.52		57	250	900	35	22
0.46		50	194	700	54	45
0.39		42	139	500	69	63
0.28		30	83	300	80	76
4V		0.49	54	281	1010	0
	0.48	53	278	1000	1	-
	0.39	42	250	900	11	-
	0.32	34	222	800	21	9
	0.28	29	194	700	29	20
	0.25	26	167	600	37	29
	0.24	25	139	500	44	37
	0.25	25	111	400	49	44
	0.26	26	83	300	54	50
	3V	0.24	25	213	765	0
0.24		24	208	750	2	-
0.22		23	194	700	6	-
0.19		18	139	500	21	14
0.14		14	69	250	33	30
2V	0.12	11	143	515	0	-
	0.12	11	139	500	1	-
	0.11	10	111	400	7	2
	0.10	9	83	300	12	9
	0.09	7	42	150	18	16

Legend

- I** Current drawn by the fan motor
- P** Power input to the fan motor
- Qv** Air flow rate
- ESP** Available external static pressure
- R** Fixed speed

7.10.2 - 42NH (continued)

42NH 6-5 (AC multi-speed version)

Speed	I	P	Qv	Qv	ESP		
					G1 Filter (Pa)	G3 Filter (Pa)	
	(A)	(W)	(l/s)	(m³/h)			
R1	1.55	350	643	2315	0	-	
	1.55	348	639	2300	4	-	
	1.48	334	611	2200	23	-	
	1.43	321	583	2100	40	9	
	1.37	309	556	2000	55	26	
	1.32	297	528	1900	67	40	
	1.27	286	500	1800	78	53	
	1.22	276	472	1700	88	65	
	1.18	266	444	1600	96	75	
	1.14	257	417	1500	103	84	
1.10	248	389	1400	109	92		
1.06	239	361	1300	115	99		
0.95	215	278	1000	132	121		
R2	1.38	298	556	2000	1	-	
	1.29	280	528	1900	31	3	
	1.22	263	500	1800	52	26	
	1.15	248	472	1700	66	44	
	1.08	234	444	1600	77	56	
	1.03	222	417	1500	85	66	
	0.97	211	389	1400	92	74	
	0.92	200	361	1300	99	82	
	0.88	190	333	1200	107	91	
	0.83	180	306	1100	116	103	
	0.79	170	278	1000	125	119	
	0.74	161	250	900	133	140	
	0.70	151	222	800	139	169	
	R3	1.28	274	454	1635	0	-
		1.24	264	444	1600	13	-
1.12		240	417	1500	41	21	
1.07		229	403	1450	51	32	
1.03		220	389	1400	60	42	
0.99		211	375	1350	66	50	
0.95		203	361	1300	73	58	
0.92		196	347	1250	78	64	
0.88		189	333	1200	84	70	
0.86		183	319	1150	90	76	
0.83		177	306	1100	95	81	
0.78		167	278	1000	107	94	
0.67		144	222	800	126	135	
R4		1.11	227	305	1097	0	-
		1.06	218	299	1075	31	15
	1.02	209	292	1050	53	37	
	0.98	201	285	1025	65	53	
	0.95	194	278	1000	72	62	
	0.92	188	271	975	76	68	
	0.89	183	264	950	80	71	
	0.87	179	257	925	85	74	
	0.86	175	250	900	89	77	
	0.84	172	243	875	94	81	
	0.83	169	236	850	99	89	
	0.81	166	229	825	104	103	
R5	0.96	188	201	723	0	-	
	0.94	183	199	715	23	11	
	0.89	175	194	700	50	36	
	0.87	170	192	690	59	49	
	0.85	166	189	680	65	59	
	0.83	163	186	670	69	66	
	0.82	160	183	660	73	72	
	0.81	158	181	650	77	75	
	0.79	155	178	640	82	78	
	0.78	153	175	630	87	81	
	0.77	151	172	620	91	83	
	0.76	149	169	610	96	87	

42NH 6-9 (EC brushless motor)

Speed	I	P	Qv	Qv	ESP	
					G1 Filter (Pa)	G3 Filter (Pa)
	(A)	(W)	(l/s)	(m³/h)		
10V	2.01	280	522	1880	0	-
	1.97	275	514	1850	8	-
	1.91	266	500	1800	21	-
	1.80	251	472	1700	45	22
	1.72	239	444	1600	67	46
	1.65	229	417	1500	87	68
	1.59	221	389	1400	105	87
	1.54	213	361	1300	121	105
	1.35	183	278	1000	157	145
	9V	1.77	238	506	1820	0
1.75		235	500	1800	4	-
1.64		221	472	1700	26	3
1.56		209	444	1600	45	24
1.49		200	417	1500	63	44
1.44		192	389	1400	80	62
1.34		177	333	1200	110	79
1.22		161	278	1000	138	95
1.13		150	250	900	151	126
8V		1.42	194	450	1620	0
	1.39	190	444	1600	4	-
	1.22	167	403	1450	37	19
	1.11	152	361	1300	64	48
	1.04	141	319	1150	86	73
	0.98	133	278	1000	105	94
	0.92	124	236	850	121	112
	0.83	111	194	700	137	129
	0.69	92	153	550	152	146
	7V	1.02	141	403	1450	0
0.97		133	389	1400	10	-
0.89		121	361	1300	29	13
0.83		112	333	1200	46	31
0.79		106	306	1100	61	48
0.75		102	278	1000	74	63
0.72		98	250	900	86	76
0.67		92	208	750	101	93
0.43		54	111	400	124	120
6V		0.71	93	361	1300	0
	0.68	88	333	1200	18	4
	0.64	83	306	1100	33	20
	0.60	78	278	1000	46	34
	0.55	73	250	900	56	46
	0.51	68	222	800	65	56
	0.47	63	194	700	75	66
	0.44	58	167	600	85	76
	0.39	45	97	350	105	100
	5V	0.50	69	319	1150	0
0.49		65	306	1100	6	-
0.46		59	278	1000	19	7
0.43		54	250	900	30	19
0.40		50	222	800	40	31
0.38		47	194	700	48	41
0.35		43	167	600	56	50
0.32		39	139	500	63	58
0.24		28	83	300	72	69
4V		0.35	46	256	920	0
	0.33	44	250	900	3	-
	0.28	36	222	800	14	5
	0.25	31	194	700	23	15
	0.23	29	167	600	30	24
	0.22	28	139	500	36	31
	0.21	25	111	400	42	38
	0.18	21	83	300	47	44
	0.17	19	75	270	49	46
	3V	0.19	22	194	700	0
0.16		19	167	600	9	3
0.14		17	139	500	16	11
0.13		15	111	400	21	17
0.11		12	56	200	29	27
2V		0.09	10	139	500	0
	0.09	10	125	450	3	-
	0.08	9	97	350	8	5
	0.08	8	69	250	12	9
	0.07	7	42	150	15	13

Legend

- I Current drawn by the fan motor
- P Power input to the fan motor
- Qv Air flow rate
- ESP Available external static pressure
- R Fixed speed

7.10.2 - 42NH (continued)

42NH7-5 (AC multi-speed version)

Speed	I	P	Qv	Qv	ESP	
					G1 Filter (Pa)	G3 Filter (Pa)
(A)	(W)	(l/s)	(m³/h)			
R1	1.86	409	785	2825	0	-
	1.80	406	778	2800	3	-
	1.74	391	750	2700	14	-
	1.67	377	722	2600	24	-
	1.61	364	694	2500	34	6
	1.56	351	667	2400	43	17
	1.45	326	611	2200	60	37
	1.34	303	556	2000	76	55
	1.25	282	500	1800	90	72
	1.16	262	444	1600	103	88
	1.08	243	389	1400	115	103
	1.00	227	333	1200	127	116
0.94	211	278	1000	138	130	
R2	1.74	385	629	2265	0	-
	1.68	371	611	2200	10	-
	1.59	350	583	2100	24	3
	1.50	331	556	2000	38	17
	1.42	313	528	1900	50	31
	1.34	296	500	1800	61	44
	1.27	281	472	1700	72	55
	1.20	266	444	1600	81	66
	1.14	252	417	1500	90	76
	1.09	240	389	1400	98	85
	1.03	228	361	1300	106	94
	0.98	217	333	1200	113	102
0.82	180	222	800	138	132	
R3	1.40	302	390	1405	0	-13
	1.39	300	389	1400	2	-11
	1.24	267	361	1300	39	27
	1.11	239	333	1200	67	56
	1.00	216	306	1100	88	78
	0.91	197	278	1000	102	94
	0.87	189	264	950	108	100
	0.84	182	250	900	113	106
	0.81	175	236	850	118	111
	0.78	169	222	800	122	116
	0.76	164	208	750	127	121
	R4	1.08	229	219	790	0
1.06		224	217	780	16	10
1.04		219	214	770	30	24
1.01		215	211	760	43	36
0.99		210	208	750	54	48
0.97		206	206	740	64	58
0.95		202	203	730	72	66
0.93		198	200	720	80	74
0.93		196	199	715	83	78
0.92		194	197	710	86	81
0.90		190	194	700	92	86
0.83		175	181	650	108	103
0.77	163	167	600	114	109	
R5	0.84	175	149	537	0	-
	0.83	172	147	530	9	5
	0.81	169	144	520	21	17
	0.80	165	142	510	32	28
	0.78	162	139	500	42	38
	0.77	159	136	490	52	48
	0.75	156	133	480	60	56
	0.74	153	131	470	68	64
	0.73	151	128	460	75	71
	0.71	148	125	450	81	78
	0.70	146	122	440	87	84

42NH 7-9 (EC brushless motor)

Speed	I	P	Qv	Qv	ESP		
					G1 Filter (Pa)	G3 Filter (Pa)	
(A)	(W)	(l/s)	(m³/h)				
10V	1.85	247	635	2285	0	-	
	1.79	247	625	2250	9	-	
	1.78	246	583	2100	40	19	
	1.71	236	528	1900	72	53	
	1.60	219	472	1700	94	78	
	1.38	185	389	1400	114	102	
	1.11	148	306	1100	126	116	
	0.86	114	222	800	136	130	
	9V	1.78	247	635	2285	0	-
		1.79	247	625	2250	9	-
1.78		246	583	2100	40	19	
1.71		236	528	1900	72	53	
1.60		219	472	1700	94	78	
1.38		185	389	1400	114	102	
1.11		148	306	1100	126	116	
0.86		114	222	800	136	130	
8V		1.38	187	547	1980	0	-
		1.38	186	542	1960	6	-
	1.36	185	528	1900	19	0	
	1.30	176	472	1700	59	43	
	1.23	166	417	1500	86	72	
	1.15	154	361	1300	104	93	
	1.04	140	306	1100	117	107	
	0.93	123	250	900	128	120	
	0.86	114	222	800	134	127	
	7V	1.11	142	517	1860	0	-
1.11		142	514	1850	2	-	
1.11		142	500	1800	13	-	
1.06		137	444	1600	48	33	
0.98		129	389	1400	70	57	
0.89		119	333	1200	85	74	
0.80		107	278	1000	97	88	
0.71		94	222	800	109	104	
0.67		88	194	700	115	110	
6V		0.85	106	469	1690	1	-15
	0.84	106	458	1650	8	-8	
	0.84	105	444	1600	16	1	
	0.82	103	417	1500	30	16	
	0.79	100	389	1400	42	29	
	0.76	96	361	1300	51	40	
	0.73	91	333	1200	59	48	
	0.66	82	278	1000	71	63	
	0.51	61	167	600	95	90	
	5V	0.59	72	406	1460	0	-13
0.58		72	389	1400	10	-3	
0.57		70	361	1300	22	11	
0.54		67	333	1200	32	22	
0.52		64	306	1100	40	30	
0.49		59	278	1000	45	37	
0.46		55	250	900	49	42	
0.42		51	222	800	53	47	
0.34		41	139	500	69	66	
4V		0.38	45	329	1185	0	-11
	0.37	44	319	1150	5	-5	
	0.35	41	278	1000	21	13	
	0.33	39	250	900	28	20	
	0.31	36	222	800	32	26	
	0.29	34	194	700	36	30	
	0.27	31	167	600	41	35	
	0.22	25	111	400	50	45	
	3V	0.22	25	247	890	1	-7
		0.21	23	222	800	11	5
0.18		20	167	600	21	17	
0.16		18	111	400	28	24	
0.16		17	83	300	31	29	
2V		0.11	11	164	590	0	-5
	0.11	11	153	550	4	0	
	0.10	10	139	500	8	4	
	0.10	9	111	400	12	9	
	0.08	7	56	200	18	14	

Legend

- I** Current drawn by the fan motor
- P** Power input to the fan motor
- Qv** Air flow rate
- ESP** Available external static pressure
- R** Fixed speed

7.11 - Water coil pressure drop

Water flow rate, l/s		0.01	0.03	0.04	0.06	0.08	0.11	0.14	0.17	0.19	0.22	0.25	0.28
Water flow rate, l/h		50	100	150	200	300	400	500	600	700	800	900	1000
42NH/NL	Water coil type	Pressure drop (kPa)											
22_	Two-pipe (7/12°C)	1	4	8	14	29	51	78	111	-	-	-	-
23_ & 27_	Two-pipe (7/12°C)	1	2	5	8	16	28	43	61	82	106	-	-
	Four-pipe cooling (7/12°C)	1	1	3	5	12	22	34	49	66	87	110	-
	Four-pipe heating (70/60°C)	1	2	4	7	15	26	40	57	77	100	-	-
32_	Two-pipe (7/12°C)	1	2	4	6	14	23	36	50	68	88	110	-
33_	Two-pipe (7/12°C)	1	2	3	5	10	17	26	37	50	64	81	99
	Four-pipe cooling (7/12°C)	1	2	4	7	15	25	37	52	70	90	113	-
	Four-pipe heating (70/60°C)	1	2	5	8	17	30	47	67	91	118	-	-

Water flow rate, l/s		0.03	0.06	0.08	0.11	0.14	0.17	0.19	0.22	0.25	0.28	0.31	0.36
Water flow rate, l/h		100	200	300	400	500	600	700	800	900	1000	1100	1300
42NH/NL	Water coil type	Pressure drop (kPa)											
42_	Two-pipe (7/12°C)	1	4	8	13	20	27	37	47	59	73	87	120
43_	Two-pipe (7/12°C)	1	4	7	12	18	24	33	42	52	64	76	105
	Four-pipe cooling (7/12°C)	2	5	10	17	25	36	48	62	77	95	114	-
	Four-pipe heating (70/60°C)	3	9	19	33	50	70	94	122	-	-	-	-
52_	Two-pipe (7/12°C)	1	3	7	11	17	24	33	42	53	65	78	108
53_	Two-pipe (7/12°C)	1	4	7	11	17	24	31	40	50	61	73	101
	Four-pipe cooling (7/12°C)	1	4	8	13	19	26	35	45	56	69	82	113
	Four-pipe heating (70/60°C)	1	1	4	7	12	19	26	35	45	57	69	99
54_	Four-pipe cooling (7/12°C)	1	4	7	11	17	24	31	40	50	61	74	101
	Four-pipe heating (70/60°C)	1	2	4	8	12	18	25	33	42	52	63	88

Water flow rate, l/s		0.06	0.11	0.17	0.22	0.28	0.33	0.39	0.44	0.50	0.56	0.61	0.67
Water flow rate, l/h		200	400	600	800	1000	1200	1400	1600	1800	2000	2200	2400
42NH	Water coil type	Pressure drop (kPa)											
63_	Two-pipe (7/12°C)	1	4	9	15	22	31	41	53	67	82	99	117
64_	Two-pipe (7/12°C)	1	3	7	12	17	25	33	42	53	65	78	93
	Four-pipe cooling (7/12°C)	1	4	8	14	22	31	41	53	67	82	98	117
	Four-pipe heating (70/60°C)	1	4	9	15	23	33	45	59	74	91	110	-
73_	Two-pipe (7/12°C)	2	5	10	17	25	35	47	60	74	91	109	-
	Four-pipe cooling (7/12°C)	1	5	10	18	28	40	54	71	89	110	-	-
	Four-pipe heating (70/60°C)	2	5	11	19	30	42	56	73	92	113	-	-
74_	Two-pipe (7/12°C)	2	5	9	14	21	28	37	47	59	71	85	100
	Four-pipe cooling (7/12°C)	2	5	10	16	25	35	47	60	76	93	111	-
	Four-pipe heating (70/60°C)	1	5	10	17	26	36	49	63	80	98	119	-

7.12 - Air flow data

Static pressure available (Pa) as a function of the air flow, m³/h (l/s)

7.12.1 - 42NL Range

42NL 2-5 (with G1 filter)

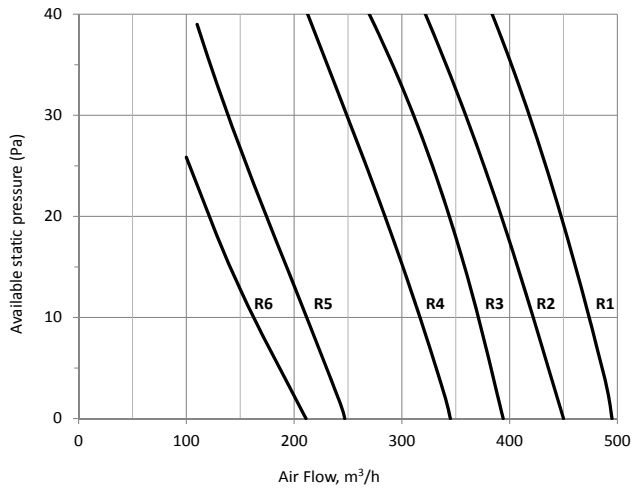

42NL 2-9 (with G1 filter)

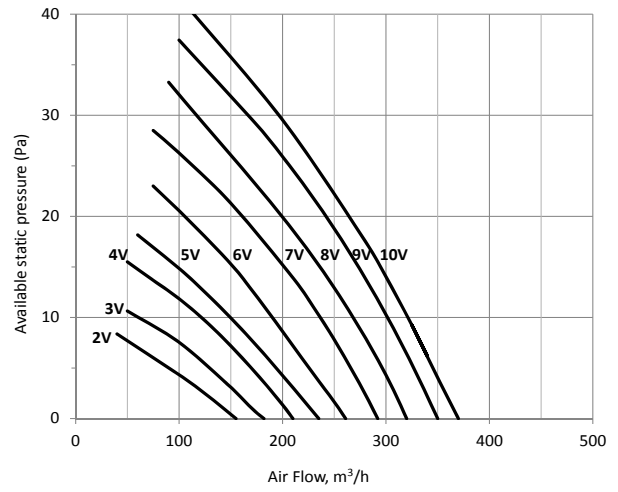

42NL 3-5 (with G1 filter)

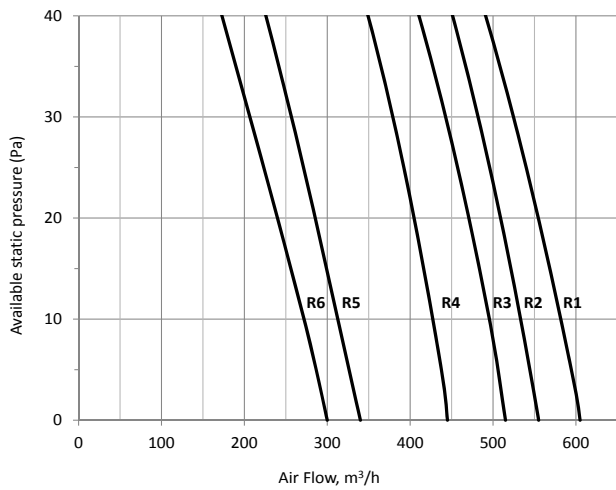

42NL 3-9 (with G1 filter)

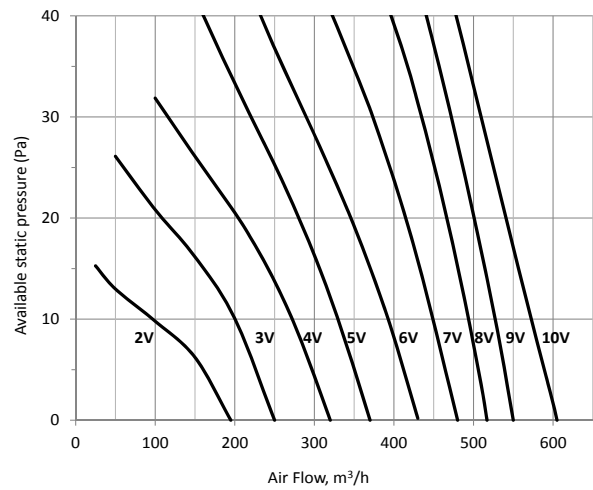

42NL4-5 (with G1 filter)

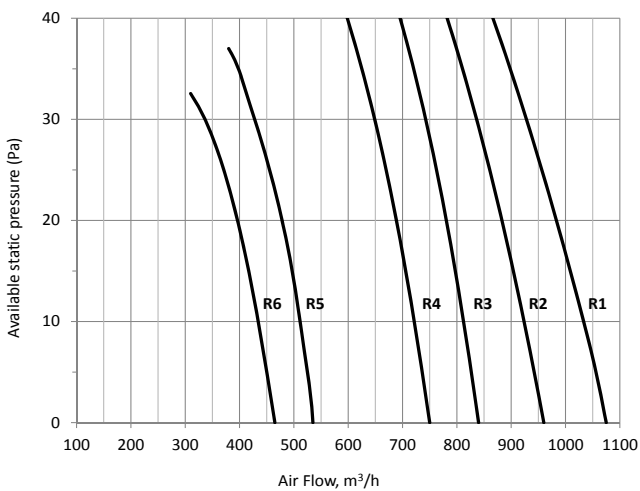

42NL 4-9 (with G1 filter)

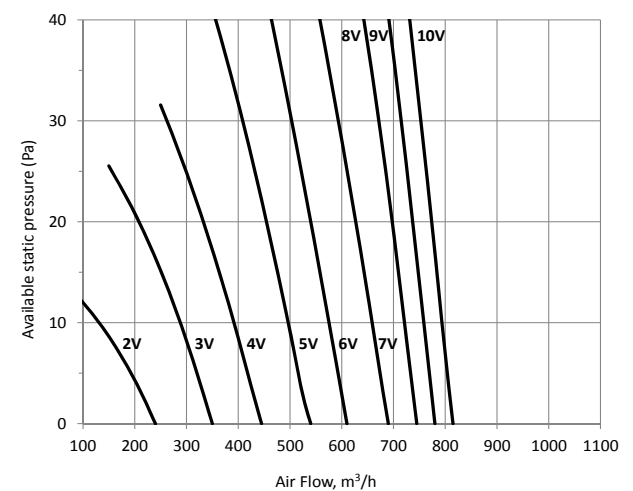

42NL 5-5 (with G1 filter)

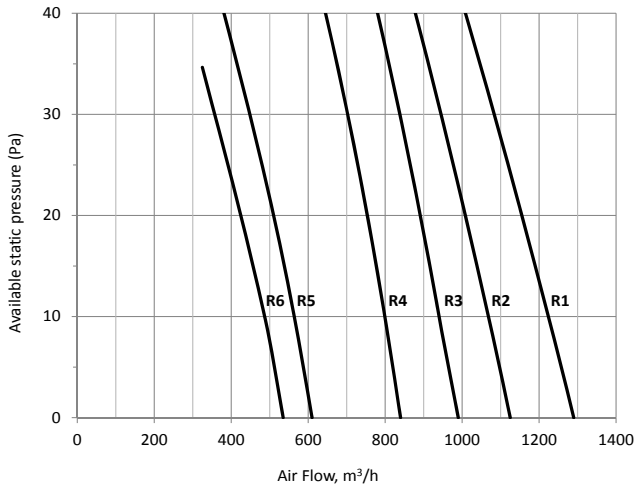

42NL 5-9 (with G1 filter)

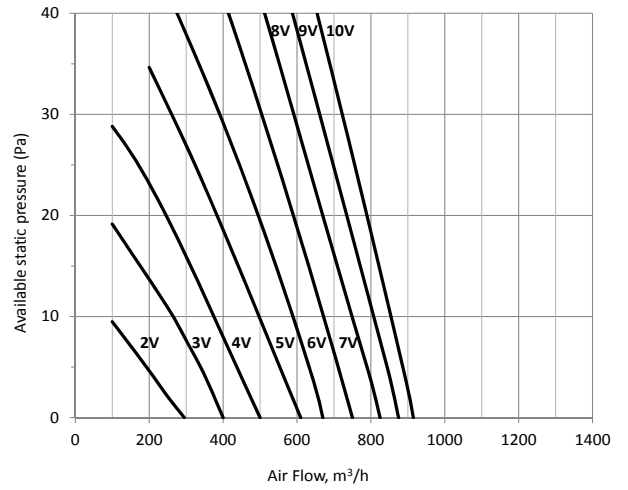

7.12.2 - 42NH Range

42NH 2-5 (with G1 filter)

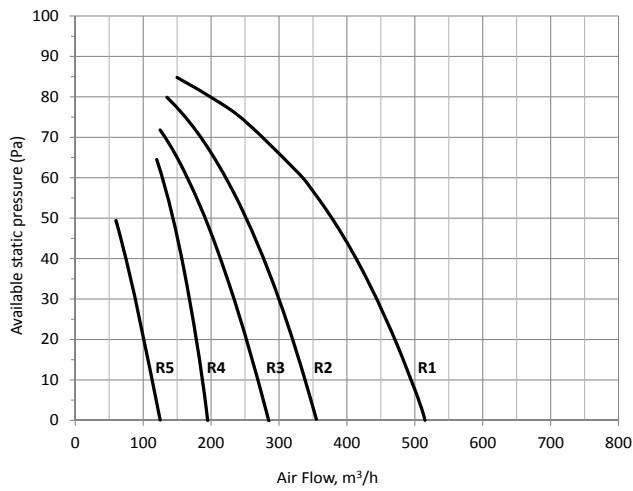

42NH 229 & 239 (with G1 filter)

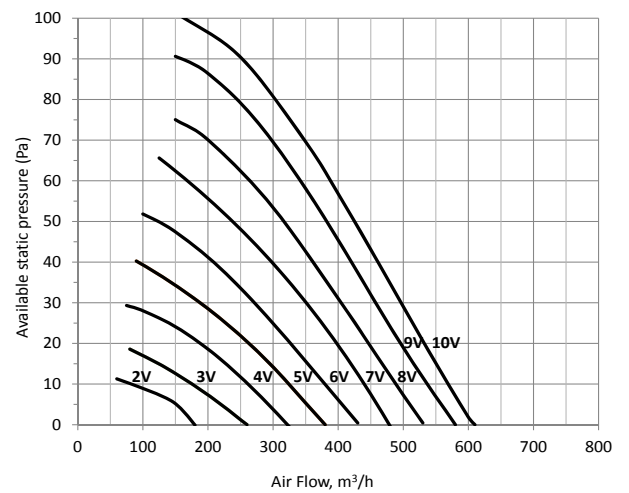

42NH 279 (with G1 filter)

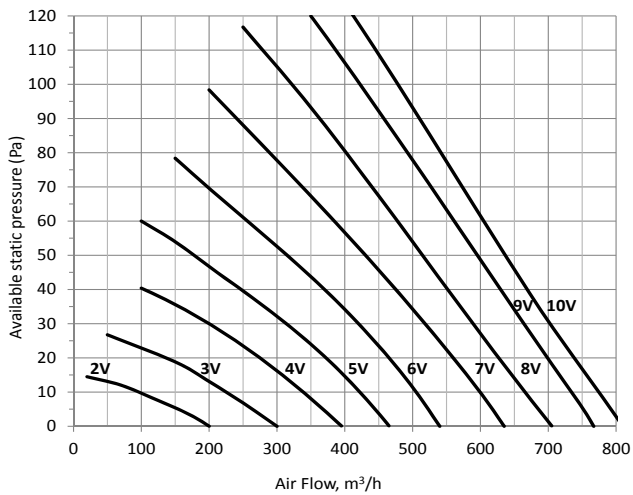

42NH 3-5 (with G1 filter)

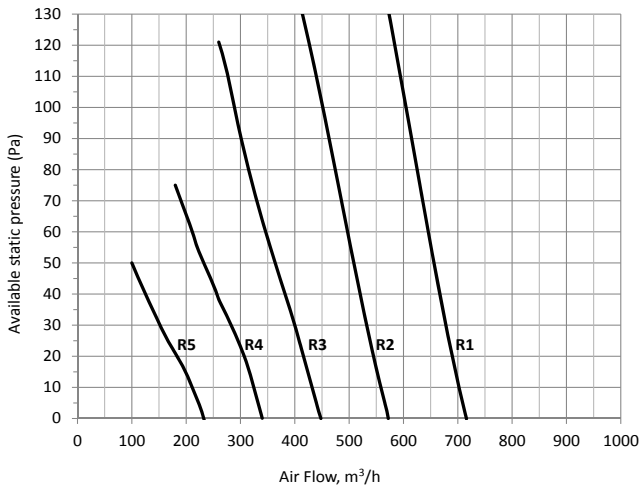

42NH 3-9 (with G1 filter)

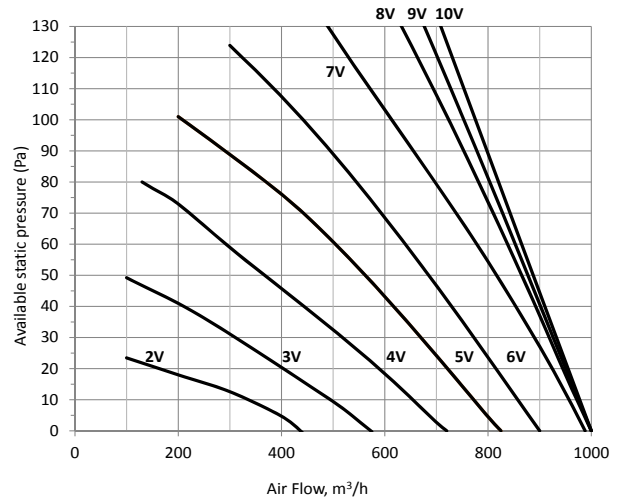

42NH 4-5 (with G1 filter)

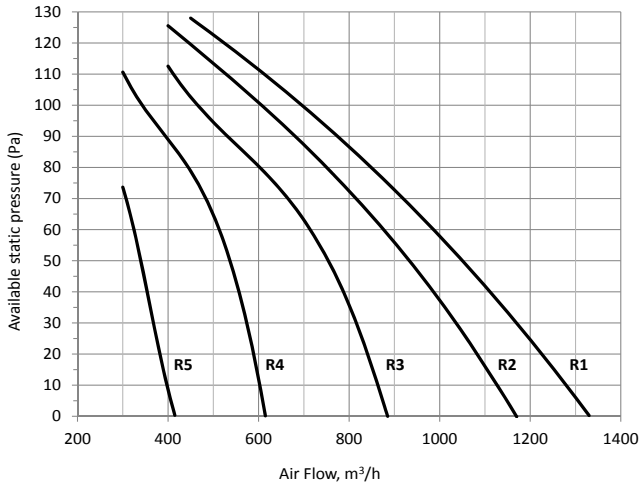

42NH 4-9 (with G1 filter)

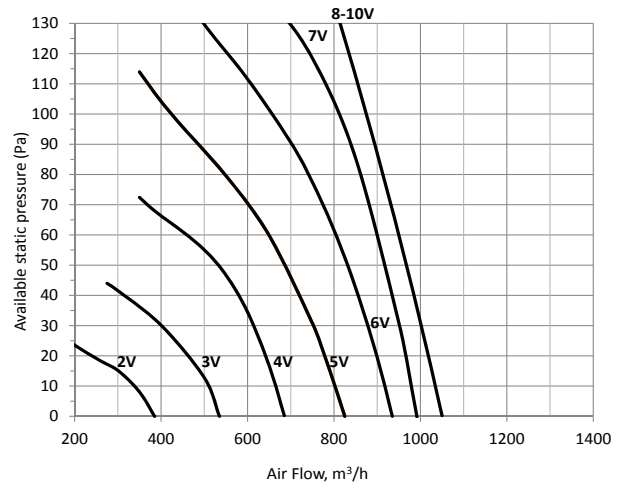

42NH 5-5 (with G1 filter)

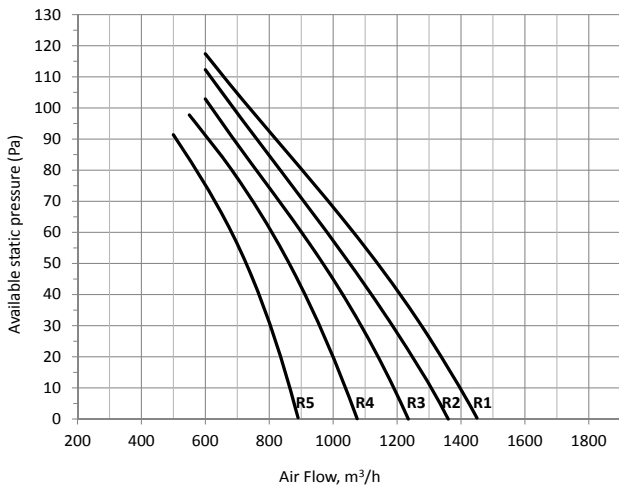

42NH 5-9 (with G1 filter)

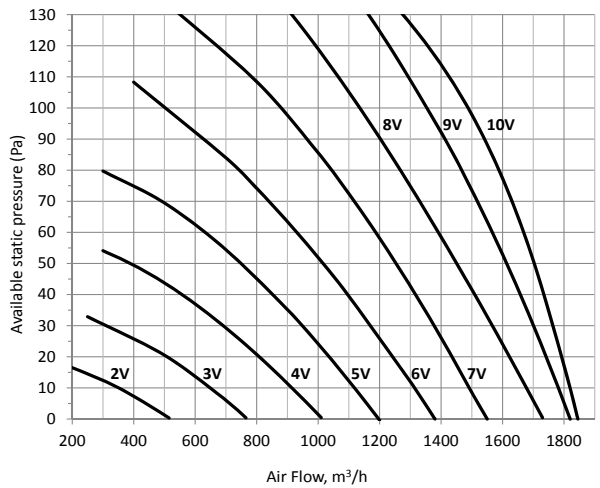

42NH 6-5 (with G1 filter)

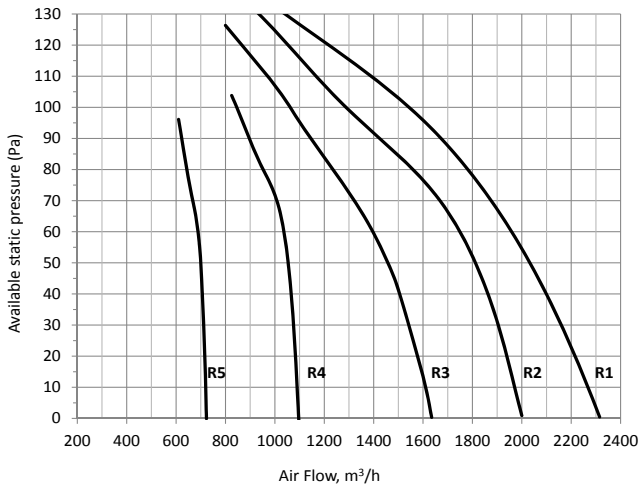

42NH 6-9 (with G1 filter)

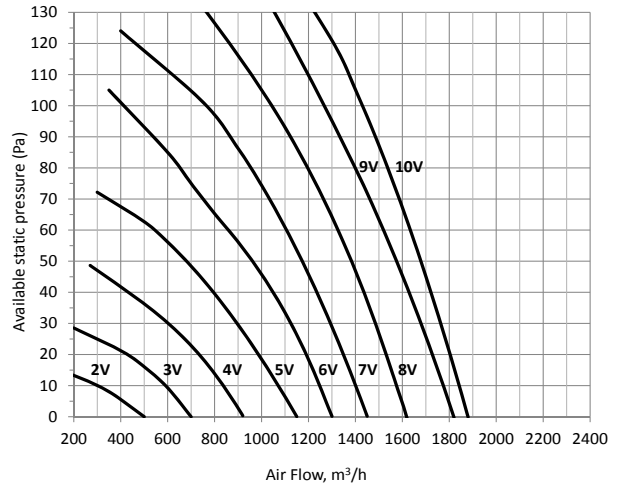

42NH 7-5 (with G1 filter)

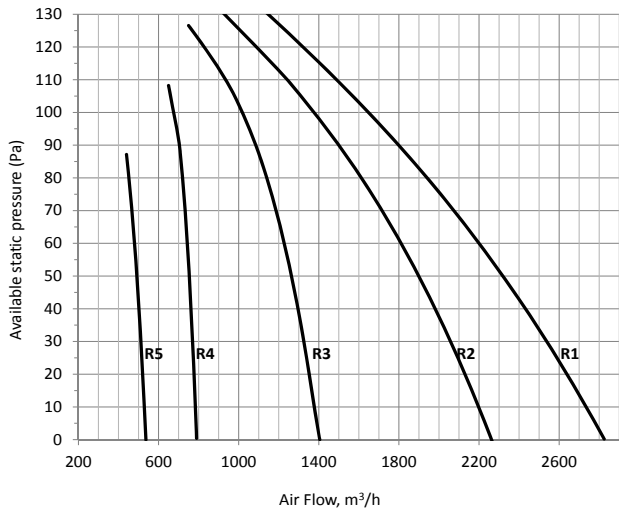

42NH 7-9 (with G1 filter)

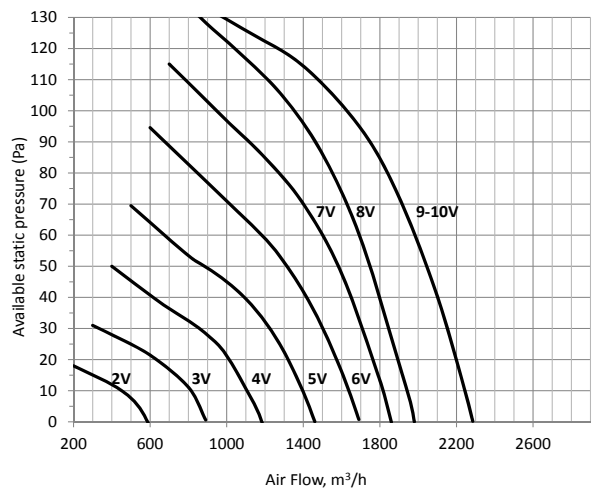

Pressure drop (Pa) for supply and return plenum boxes as a function of the number of spigots

42NH & NL - Size 2								
Air flow, l/s		28	56	83	97	111	125	139
Air flow, m ³ /h		100	200	300	350	400	450	500
Diameter 160 mm		Pressure drop (Pa)						
1 spigot	Return	3	6	10	13	16	20	23
	Supply	4	7	12	15	18	22	26
2 spigots	Return	1	3	4	5	7	8	10
	Supply	2	3	5	6	7	9	11
3 spigots	Return	1	1	2	2	3	3	4
	Supply	1	1	2	3	3	4	5
Diameter 200 mm		Pressure drop (Pa)						
1 spigot	Return	0	2	4	6	7	9	12
	Supply	3	5	8	10	12	15	18
2 spigots	Return	0	1	1	2	2	2	3
	Supply	1	1	2	2	3	4	4
3 spigots	Return	0	0	1	1	1	1	1
	Supply	0	0	1	1	1	2	2

42NH & NL - Size 3								
Air flow, l/s		28	83	139	194	222	250	278
Air flow, m ³ /h		100	300	500	700	800	900	1000
Diameter 160 mm		Pressure drop (Pa)						
2 spigots	Return	1	3	6	9	11	13	15
	Supply	4	12	23	36	44	52	61
3 spigots	Return	1	2	4	7	8	10	12
	Supply	3	9	17	28	34	40	47
4 spigots	Return	0	1	2	4	4	5	6
	Supply	2	5	9	14	18	21	25
Diameter 200 mm		Pressure drop (Pa)						
1 spigot	Return	0	2	5	10	13	16	20
	Supply	1	5	15	30	39	49	61
2 spigots	Return	1	2	4	6	7	9	10
	Supply	3	8	15	24	29	35	41
3 spigots	Return	0	1	2	3	3	4	4
	Supply	1	3	7	10	13	15	18
4 spigots	Return	0	0	1	1	2	2	2
	Supply	1	2	4	6	7	8	10

42NH & NL - Size 4								
Air flow, l/s		56	83	139	194	250	306	375
Air flow, m ³ /h		200	300	500	700	900	1100	1350
Diameter 160 mm		Pressure drop (Pa)						
3 spigots	Return	0	1	2	4	6	9	13
	Supply	1	2	6	11	17	26	38
4 spigots	Return	0	0	1	2	3	5	7
	Supply	1	1	3	6	10	15	22
5 spigots	Return	0	0	1	1	2	3	5
	Supply	0	1	2	4	6	9	14
Diameter 200 mm		Pressure drop (Pa)						
2 spigots	Return	0	1	2	3	5	8	12
	Supply	1	2	5	10	16	24	36
3 spigots	Return	0	0	1	1	2	4	5
	Supply	1	1	2	4	7	10	16
4 spigots	Return	0	0	0	1	1	2	3
	Supply	0	1	1	2	4	6	9

42NH & NL - Size 5										
Air flow, l/s		56	139	208	278	347	417	486		
Air flow, m ³ /h		200	500	750	1000	1250	1500	1750		
Diameter 160 mm		Pressure drop (Pa)								
3 spigots	Return	2	7	11	16	21	27	33		
	Supply	6	13	22	35	50	69	91		
4 spigots	Return	1	3	5	8	12	16	20		
	Supply	6	10	15	20	26	34	42		
5 spigots	Return	1	2	4	7	9	12	16		
	Supply	5	8	12	16	21	27	33		
6 spigots	Return	1	2	3	4	6	8	11		
	Supply	3	5	8	11	14	18	22		
Diameter 200 mm		Pressure drop (Pa)								
2 spigots	Return	2	6	9	14	18	23	29		
	Supply	5	11	19	30	45	62	82		
3 spigots	Return	1	3	5	7	10	14	18		
	Supply	5	9	13	18	23	30	37		
4 spigots	Return	0	2	3	4	6	8	10		
	Supply	3	5	7	10	13	17	21		
5 spigots	Return	0	1	2	3	4	5	6		
	Supply	2	3	4	6	8	10	13		
6 spigots	Return	0	1	1	2	2	3	4		
	Supply	1	2	3	4	6	7	9		

42NH - Size 6										
Air flow, l/s		83	167	278	361	444	556	639		
Air flow, m ³ /h		300	600	1000	1300	1600	2000	2300		
Diameter 200 mm		Pressure drop (Pa)								
3 spigots	Return	2	3	6	8	11	15	19		
	Supply	3	7	12	16	20	26	30		
4 spigots	Return	1	2	3	5	6	9	11		
	Supply	2	4	6	9	11	14	17		
5 spigots	Return	1	1	2	3	4	5	7		
	Supply	1	2	4	5	7	9	11		
Diameter 250 mm		Pressure drop (Pa)								
2 spigots	Return	2	3	6	8	10	14	18		
	Supply	3	6	11	14	18	24	28		
3 spigots	Return	1	1	2	3	4	6	8		
	Supply	1	3	5	6	8	10	12		
4 spigots	Return	0	1	1	2	2	3	4		
	Supply	1	1	2	3	4	6	7		

42NH - Size 7										
Air flow, l/s		139	278	417	500	556	694	778		
Air flow, m ³ /h		500	1000	1500	1800	2000	2500	2800		
Diameter 200 mm		Pressure drop (Pa)								
4 spigots	Return	1	2	3	5	6	8	10		
	Supply	1	5	12	18	22	35	44		
5 spigots	Return	0	1	2	3	4	5	6		
	Supply	1	3	8	11	14	22	28		
6 spigots	Return	0	1	2	2	2	3	4		
	Supply	1	2	5	8	10	15	19		
Diameter 250 mm		Pressure drop (Pa)								
3 spigots	Return	1	1	3	3	4	6	7		
	Supply	1	4	9	13	16	25	32		
4 spigots	Return	0	1	1	2	2	3	4		
	Supply	1	2	5	7	9	14	17		
5 spigots	Return	0	0	1	1	1	2	2		
	Supply	0	1	3	4	5	9	11		

8 - OPERATING LIMITS

	Cooling mode	Heating mode
Water circuit	Min. inlet Temperature > 5°C < 40% ethylene / propylene glycol Water side pressure < 15.5 bar (1550 kPa)	Max. inlet Temperature < 80°C < 40% ethylene / propylene glycol Water side pressure < 15.5 bar (1550 kPa)
Ambient temperature and humidity	T < 27°C / 65% relative humidity or Humidity weight < 14.7 g/kg dry air	T < 40°C
Supply air temperature	T > 12°C with maximum ambient humidity conditions (14.7 g/kg dry air)	T < 60°C with supply plenum and spigots application Recommandation to avoid stratification T < 35°C
EC Motor - Electrical input	Min: 216V Max: 244 V 60 or 50 Hz -1ph	Min: 216V Max: 244 V 60 or 50 Hz -1ph
AC motor - Electrical input	Min: 207V Max: 253 V 60 or 50 Hz -1ph (60Hz not available for 42NH325 & 335)	Min: 207V Max: 253 V 60 or 50 Hz -1ph (60Hz not available for 42NH325 & 335)

NOTE: All performances data certified by Eurovent are based on 50Hz application.
Carrier doesn't ensure the same performances when the unit operates at 60Hz; the RPM and power input of the fan-motor are usually higher.

9 - SPECIFICATION GUIDE 42NL/42NH

The Carrier 42NL/H is a new Hydronic ducted Fan Coil suitable for all application available in two version:

- 42NL: low pressure mainly for hotel application
- 42NH: high pressure mainly for office application

This new range is available in 6 sizes of chassis:

- Sizes 2/3/4/5: low height of 235 mm cooling capacity up to 6 kW
- Sizes 6/7: medium height of 285 mm cooling capacity from 5 to 12 kW

The 42NL/H_AC/LEC unit shall comply with the requirements of the following European regulations

- Machinery 98/37/CE revised,
- Low voltage directive 2006/95/CEE
- Electromagnetic Compatibility directive 2004/108/CEE and the applicable recommendations of the European standards.
- Machine safety: electrical equipment in machines, general regulations, EN 60204-1,
- Electromagnetic Emissions radiated: IEC 61000-3-3
- Electromagnetic Emissions canalised: IEC 61000-6-4
- Electromagnetic immunity: IEC 61000-6-2
- Regulation EC327/2011 with regard to EcoDesign requirements for electric driven fans

General description

Unit(s) shall be designed, manufactured and tested in a facility with a quality assurance system certified ISO 9001 and with an environment management certified ISO 14001.

Unit(s) shall be certified by Eurovent.

Unit(s) shall be run tested at the factory before shipment

Technical specification

Chassis

- The 42NL/H is made of galvanized sheet metal with full high efficiency insulation to optimized the thermal and phonic performances of the unit
- In order to comply with the various local regulations (fireclass) the 42NL/H unit is available with both class M1 type insulation (according to NF P 92-507) and Euroclass level B-s3-d0 (according to EN 13501).
- It is also equipped with antivibration-mounts as standard.

Fan-motors

- The 42NL/H shall be equipped with centrifugal forward-curved, double inlet, simple, double or triple wheel fans with either:
 - Low Energy Consumption motor (LEC) EC motor that meet the new building energy performance objectives thanks to auto-adaptive air flow rate adjustment from 0 to 100% ensuring perfect cooling and heating conditions in the room.
 - Multi-speed asynchronous motor compliant with Erp2015 regulation, with internal overload protection

Heating or Cooling Coil

- 42NL/42NH units shall be equipped with either a cooling/ heating changeover coil, a monobloc heating and cooling coil or a cooling coil and an electric heater. The water coils shall be provided with manual air purge valves
- The cooling and heating coils shall be made from copper tubes and aluminum fins. The maximum water side working pressure shall not exceed 10 bar (1000 kPa).

Filter

- The 42NL/H shall at least be provided with filter G1 class according to EN 779
- Other filtration available: filter G3 or pleated filter M5 class according to EN779

Controller range

- Electronic thermostats A-B-C-D types for all application
 - Type A: 2 pipes with AC motor
 - Type B: 4 pipes or 2 pipes with electric heaters with AC motor
 - Type C: 2 pipes with EC motor
 - Type D: 4 pipes or 2 pipes with electric heaters with EC motor
- NTC Controller
 - Communication PID controller compatible with Aquasmart Evolution System package (proprietary protocol CCN)
 - Manage the motorized louvers of the grill in manual or automatic
 - Manage the EC motor to optimise the comfort
 - Manage a CO₂ sensor to improve Air Quality
- WTC Controller
 - Open Communication protocol BACnet or LON
 - Communication PID controller
 - Large range of user interfaces wall mounted or remote
 - Manage the motorized louvers of the grill in manual or automatic
 - Manage the EC motor to optimise the comfort
 - Manage a CO₂ sensor to improve Air Quality
 - Optional Light and/or Blinds management modules from same user interface
 - Large range of sensors (light, presence, etc.)

Valve options

- Control Two or four-ways bodies with 230V power supply:
 - On/Off 230V actuator
 - Floating 3-point 230 V actuator
- Control and balancing Two-way valves. Two-in-one designed valves enabling both the setting of the nominal waterflow in the fan-coil and the waterflow control with the NTC or the WTC, with 230 V power supply:
 - On/Off 230V actuator
 - Floating 3-point 230V actuator



Order No.: 10008-20, 08.2015. Supersedes order No.: 10008-20, 12.2014.
Manufacturer reserves the right to change any product specification without notice.



Quality and Environment
Management Systems
Approval

Printed in the European Union.